

**Maximum SPL:**

130 dB

**S/N ratio:**

68 dB

**Dynamic range:**

106 dB

**Power supply:**

9~52 VDC

**Current consumption:**

5 mA

**Dimensions:**

length 4.33" (110mm) x  
width 3.07" (78mm) x  
height 0.94" (24mm)

**Net weight:**

6.35 oz. (180 g)

**Type:**

Back-electret condenser  
microphone

**Pickup pattern:**

Half-cardioid  
(or cardioid in half space)

**Frequency response:**

50 Hz to 20 kHz

**Sensitivity:**

-35 dBV/Pa

**Rated impedance:**

50 Ohms

**Minimum load impedance:**

1k Ohms

**Features:**

- Back-electret condenser element
- Unidirectional (half-cardioid above boundary)
- Compact, low profile design
- Rugged construction
- Shock-absorbing mounting pad, quiet operation
- Black non-reflecting finish
- Detachable cable
- Operational from 9 to 52 VDC phantom power source

**Description**

Specifically designed for a low profile, surface-mounted configuration, the PSM 3 is ideally suited for stage performances as well as video conferencing and other boundary applications. The PSM 3 contains a wide range of unidirectional condenser capsules mounted in its rugged housing, allowing it to become part of the acoustical boundary when placed on a flat, reflective surface.

**Operation**

When a conventional microphone is used near a large, reflecting surface, the sound reflected from the surface reaches the capsule at a slightly different time than that of the direct source.

Depending on the distance and the frequency, the reflected sound may either add to or subtract from the direct source, resulting in a number of peaks and dips in the output response. This is also referred to as Comb Filter Effect and can seriously degrade the reproduced sound.

When the PSM 3 is placed on the reflecting surface, it becomes part of the reflecting boundary and the interior reflections are eliminated. The results are a cleaner, smoother, more natural sound.

Another advantage to using the PSM 3 in surface mounted (or boundary layer) operation is that the sound pressure at the surface is approximately twice the value as it would be in free space (no reflective surfaces). This results in a 6 dB increase in output level and an added 6 dB of signal-to-noise ratio.

With a unidirectional surface-mounted microphone such as the PSM 3, there is also a 3 dB improvement in directivity, which helps both feedback rejection and a control of unwanted sound.



**APPLICATIONS AND USE**

The low profile, rugged construction and excellent performance of the PSM 3 make it ideally suited for any sound reinforcement, recording or video/teleconferencing in which a unidirectional surface microphone would be an advantage: in footlight areas or news desks, on church altars or conference tables, placed inside grand pianos or in front of instrument amplifiers.

For optimum sound reproduction with the PSM 3 (or any similar microphone), several important factors must be recognized:

1) The low frequency performance is directly related to the size and shape of the reflecting surface (i.e., the larger the surface, the better the low frequency reproduction). For full music reproduction, the sides of the surface should be at least 10'. For good speech performance, the surface could be as short as 3'.

2) For best results, the surface must be acoustically reflective. Adequate results cannot be achieved with carpeted or padded surfaces.

3) The optimum working angle between the source and the mounting surface is from approximately 10° to 60°. Under no circumstances should the source be below the reflective or mounting surface.

**ARCHITECTURAL & ENGINEERING SPECIFICATIONS**

The microphone shall be a back-electret condenser type so constructed that it becomes part of the acoustic boundary when placed on a reflecting surface. The frequency response shall be 50 Hz to 20 kHz when used on an infinite boundary. The pickup pattern shall be half-cardioid (or cardioid in half space) with rear response typically down 20 dB or greater. The microphone shall have an output level of -35 dBV and nominal impedance is 500 Ohms. This microphone shall have a non-reflecting,

low gloss black finish. The microphone shall include an interfacing cable 10' (3.12 m) in length with a Q-G (TA3F) on one end and XLR microphone connector on the other.

The microphone shall be 4.33" (110 mm) in length, 3.07" (78 mm) wide and 0.94" (24 mm) in height, and shall weigh 6.35 oz. (180 g). The microphone shall operate properly with any 9-52 volt phantom power supply. The microphone shall be a Peavey PSM 3.

**2 YEAR LIMITED WARRANTY**

**NOTE:** For details, refer to the warranty statement. For copies of this statement, contact Peavey Electronics Corporation, at P.O. Box 2898, Meridian, Mississippi 39301-2898, or go online to [www.peavey.com](http://www.peavey.com).

# SPECIFICATIONS

# PSM™ 3

## Pickup Patterns

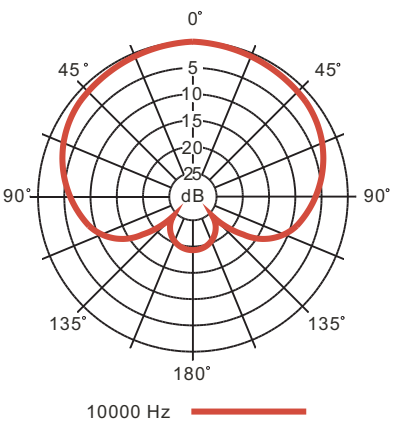
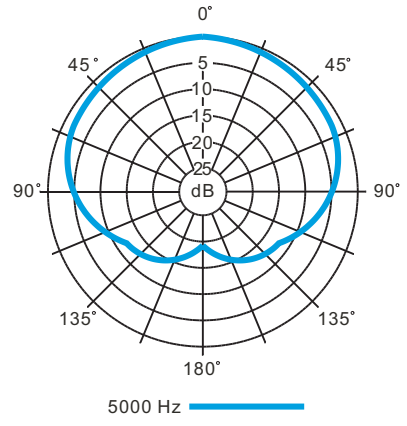
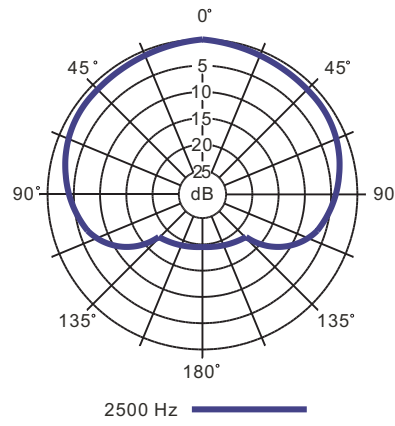
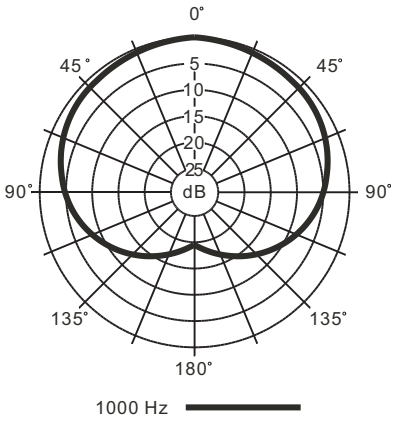
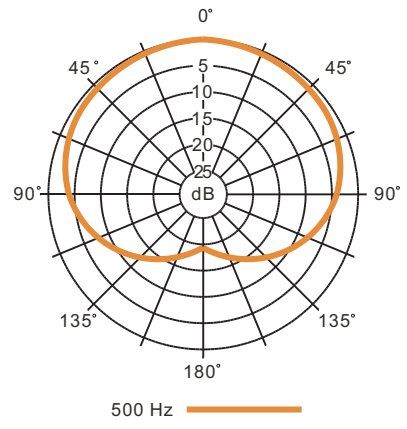
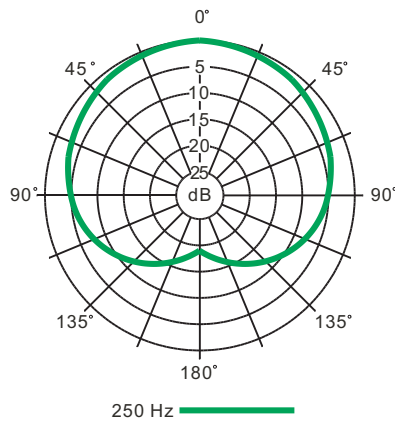
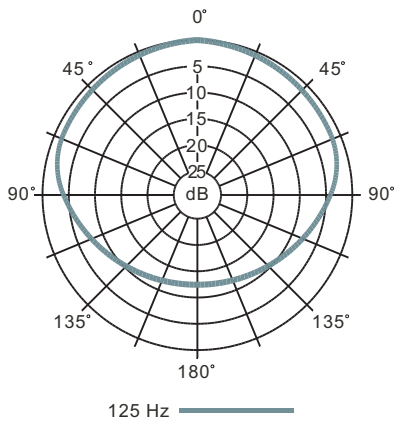

## Frequency Response

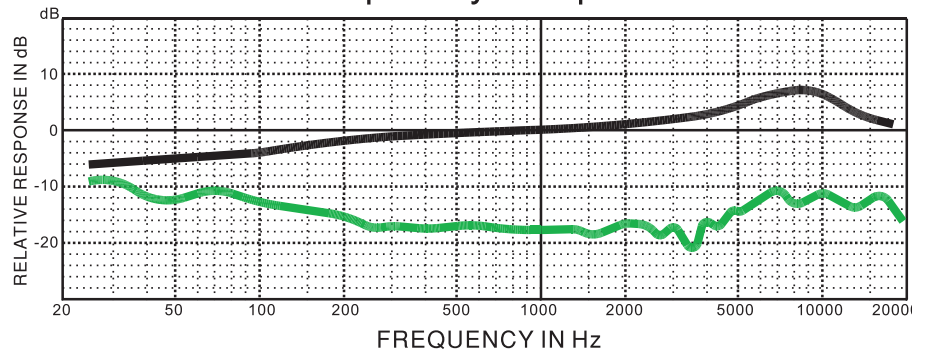



Features and specifications subject to change without notice.

Peavey Electronics Corporation • 711 A Street • Meridian • MS • 39301

(601) 483-5365 • FAX (601) 486-1278 • [www.peavey.com](http://www.peavey.com)

EX 000004