

## Specifications FMW™ 12 floor monitor



**Frequency response, 1 meter on-axis,  
swept-sine in anechoic environment:**

120 Hz - 14 kHz ( $\pm 3$  dB)

**Usable low frequency limit  
(-10 dB point):**

73 Hz

**Power handling:**

Full Range:

500 W continuous  
1,000 W program  
2,000 W peak

Low Frequency Section:

500 W continuous  
1,000 W program  
2,000 W peak

High Frequency Section:

60 W continuous  
120 W program  
240 W peak

**Sound pressure level, 1 Watt,  
1 meter in anechoic environment:**

Full Range:

100.0 dB SPL, (2.83 V input)

Low Frequency Section:

100.0 dB SPL, (2.83 V input)

High Frequency Section:

106.0 dB SPL, (2.83 V input)

**Maximum sound pressure level  
(1 meter):**

Full Range:

125.0 dB SPL continuous  
131.0 dB SPL peak

Low Frequency Section:

126.0 dB SPL continuous  
132.0 dB SPL peak

High Frequency Section:

123.8 dB SPL continuous  
129.8 dB SPL peak

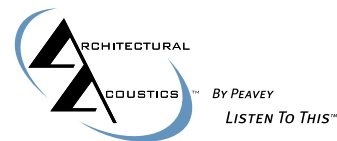

# Specifications FMW™ 12 floor monitor

**High Frequency Section:**  
 123.8 dB SPL continuous  
 129.8 dB SPL peak

**Transducer complement:**

**Low Frequency Section:**  
 1x 12 in. woofer, sealed  
 1208 SPS-8 BWX  
**High Frequency Section:**  
 1x .875 in. exit/51 mm voice coil  
 compression driver on CD horn  
 RX™ 22 on a CH®-3

**Harmonic distortion:**

**1% rated power**  
**2nd Harmonic:**  
 100 Hz: 1.66%  
 1 kHz: 0.49%  
**3rd Harmonic:**  
 100 Hz: 0.63%  
 1 kHz: 0.44%  
**10% rated power**  
**2nd Harmonic:**  
 100 Hz: 4.05%  
 1 kHz: 2.13%  
**3rd Harmonic:**  
 100 Hz: 2.67%  
 1 kHz: 0.52%

**Crossover frequency (internal passive):**

Low Frequency - High Frequency:  
 1,350 Hz

**Recommended active crossover frequency region and slope:**

Low Frequency - High Frequency:  
 1,600 Hz at 18 dB/octave

**Time offset:**

Low Frequency: 0.00 ms  
 High Frequency: 0.27 ms

**Impedance (Z):**

**Full Range:**  
 Nominal: 8.0 Ω  
 Minimum: 6.2 Ω  
**Low Frequency:**  
 Nominal: 8.0 Ω  
 Minimum: 6.9 Ω  
**High Frequency:**  
 Nominal: 8.0 Ω  
 Minimum: 7.1 Ω

**Input connections:**

2x 1/4 in. phone jack and 1x Neutrik®  
 NL4 Speakon® (bi-amp only)

**Enclosure materials and finish:**

3/4" OSB painted off-white

**Mounting provisions:**

This unit is not designed for over-  
 head suspension  
 SA 1 stand mount adapter

**Dimensions (H x W x D):**

**Front:**  
 15.25 in. x 22.25 in. x 15.00 in.  
 387 mm x 565 mm x 381 mm

**Net weight:**

50 lbs. (22.7 kg)

**Features:**

- Two-way, full range/biampable PA enclosure
- Sound Guard HF driver protection circuit
- RX22 driver with a 2" titanium diaphragm coupled to a CH 3 90° x 45° constant-directivity horn
- 12" BWX Black Widow® with Kevlar® cone and field-replaceable basket
- Integral stand adapter
- Neutrik biamp jack
- 30° or 45° baffle angle

**Description**

This high power handling, two-way floor monitor loudspeaker system is comprised of a 12" BWX woofer with a Kevlar impregnated cone and an RX 22 compression driver coupled to a CH 3 constant directivity horn. This unit can be driven in full-range mode simply by plugging into one of the two 1/4" phone jacks on the input plate. A Neutrik

Speakon connector is provided as an input for biamp operation. The unique design of the enclosure allows the baffle to be angled at either 30° or 45° from the floor. The FMW 12 is constructed of 3/4" OSB and painted with an off-white textured paint. A cloth covered, powder coated expanded metal grille covers the front of the enclosure to protect the drivers from unforeseen accidents. A stand mount adapter is also included in one of the ends of the enclosure. This will allow it to be used as a PA type loudspeaker if needed.

Sound Guard III is the redesign of Peavey's proprietary circuit for high frequency driver protection for the new RX 22 compression driver. This is an integral part of the crossover for the FMW 12. The input signal is routed through the Sound Guard III circuit in both full-range and biamp modes of operation. When the high frequency drive level to the FMW 12 exceeds a predetermined threshold, the Sound Guard III circuit is engaged. The effect that this has is to subtly decrease the signal level going to the RX 22 so that it will not be damaged due to long-term overpowering. Short duration transients will not be attenuated by Sound Guard III and have the possibility to damage the

**Amplitude Response (1W 1m On-Axis)**

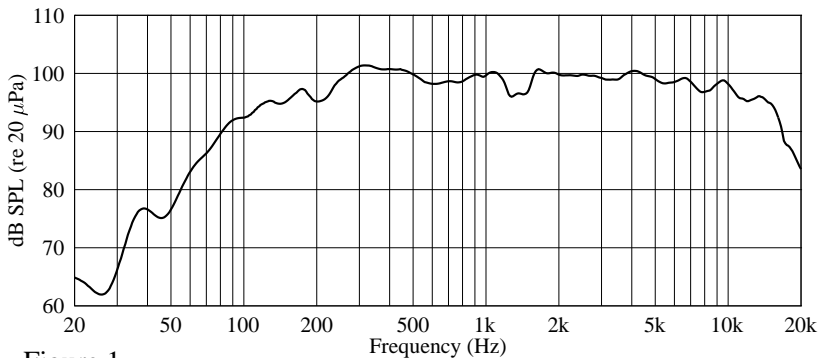

Figure 1

**Impedance**

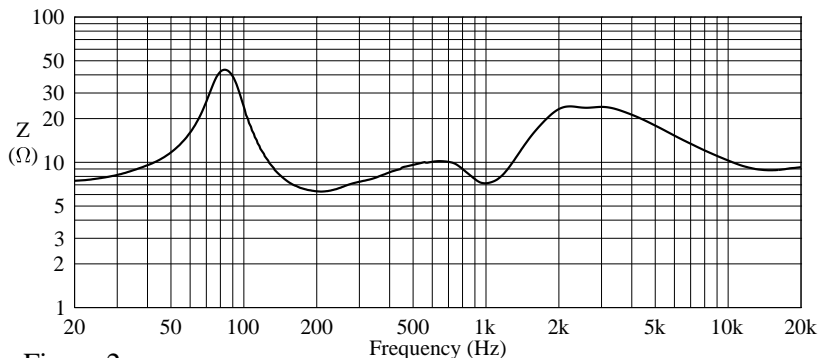

Figure 2

# Specifications FMW™ 12 floor monitor

RX 22. The Sound Guard III circuit is a dynamic circuit that will attenuate the signal more the larger the signal is, very similar to a compressor. This is accomplished through the use of a specially selected dynamically resistive light bulb. If the bulb in your Sound Guard III should ever burn out a replacement may be obtained from an Authorized Peavey Service Center. However, if a Peavey replacement bulb is not readily available, a Sylvania SK3 bulb may be located at various loudspeaker or electronics parts stores.

### Frequency response

This measurement is useful in determining how accurately a given unit reproduces an input signal. The frequency response of the FMW 12 is measured at a distance of 1 meter using a 1 Watt (into the nominal impedance) swept-sine input signal. As shown in figure 1, the selected drivers in the FMW 12 combine to give a smooth frequency response from 120 Hz - 14 kHz.

### Power handling

There are many different approaches to power handling ratings. Peavey rates this loudspeaker system's power handling using a full-range form of the AES Standard 2-1984. Using audio band 20 Hz to 20 kHz pink noise with peaks of four times the RMS level, this strenuous test signal assures the user that every portion of this system can withstand today's high technology music. This rating is contingent upon having a minimum of 3 dB of amplifier headroom available.

### Harmonic distortion

Second and third harmonic distortions vs. frequency are plotted in figures 3 and 4 for two power levels, ten percent (10%) of rated input power and either one percent (1%) of rated input power or one Watt, whichever is greater. Distortion is read from the graph as the difference between the fundamental signal (frequency response) and the desired harmonic. As an example, a distortion curve that is down 40 dB from the fundamental is equivalent to 1% distortion.



### Mounting Warning:

This unit is not designed for overhead suspension.

### Architectural & engineering specifications

The loudspeaker system shall have an operating bandwidth of 120 Hz - 14 kHz. The nominal output level shall be 98.0 dB when measured at a distance of one meter with an input of one Watt. The nominal impedance shall be 8.0 Ohms. The maximum continuous power handling shall be 500 Watts, maximum program power of 1,000 Watts and a peak power input of at least 2,000 Watts, with a minimum amplifier headroom of 3 dB. The nominal radiation geometry shall be 45 degrees in the horizontal plane and 90 degrees in the vertical plane. The outside dimensions shall be 15.25 inches high by 22.25 inches wide by 15.00 inches deep.

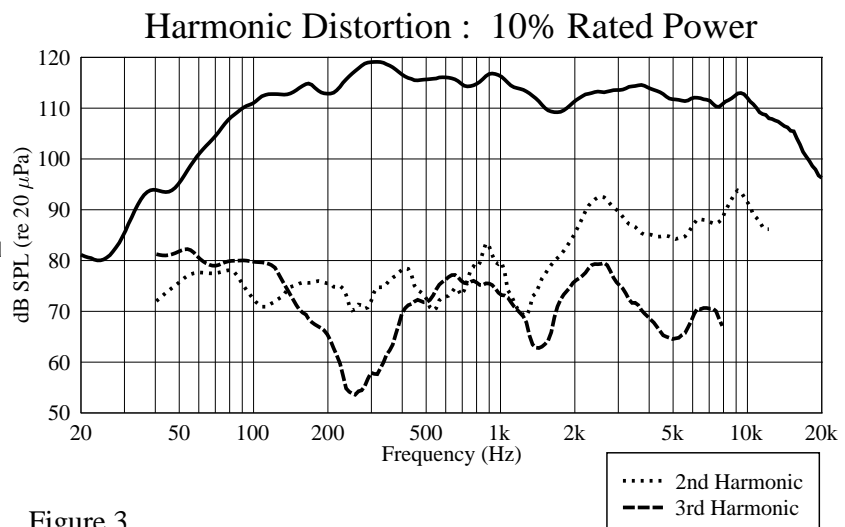

Figure 3

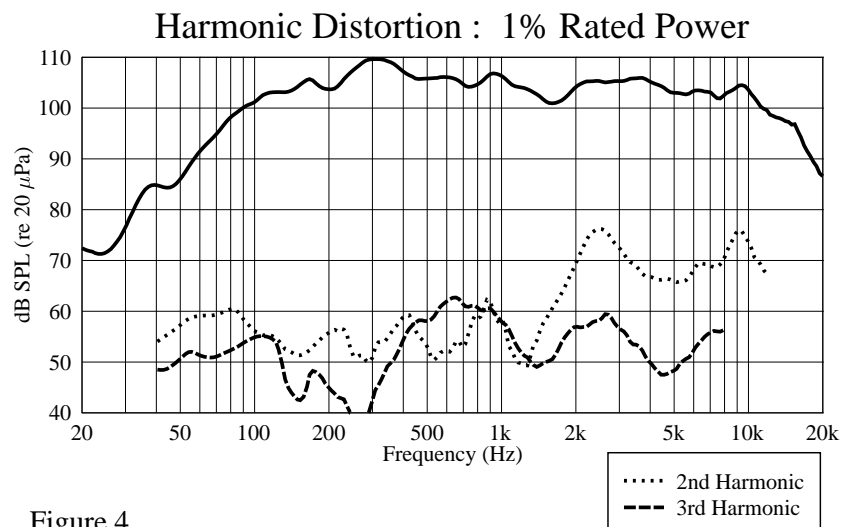

Figure 4

The weight shall be 50 pounds. The  
loudspeaker system shall be a Peavey  
Architectural Acoustics model FMW 12.

**5 YEAR LIMITED WARRANTY**  
**NOTE:** For details, refer to the  
warranty statement. Copies of  
this statement may be obtained by

contacting Peavey Electronics  
Corporation, P.O. Box 2898,  
Meridian, Mississippi 39301-2898.

**FMW™ 12 INPUT**

**FMW™ 12**

---

MAX POWER: 1000 W PROGRAM



PIN 1+ (+) POS.  
PIN 1- (-) NEG.

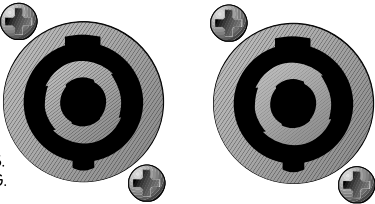

**FULL RANGE INPUTS**



8 OHMS

50 LBS.  
22.7 kg.

**WARNING:** THIS SPEAKER SYSTEM CAN PERMANENTLY DAMAGE  
HEARING! USE EXTREME CARE SETTING MAXIMUM LOUDNESS

HF DRIVER PROTECTED BY SOUNDGUARD™ III  
BUILT UNDER U.S. PATENT NO. 6,064,745

**CE**

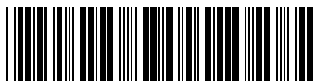

**80302433**

Peavey Electronics Corporation • 711 A Street • Meridian, MS 39301  
601-483-5376 • Fax 601-486-1678 • <http://aa.peavey.com>  
©2001 Printed in the U.S.A. 10/01

