

SPECIFICATIONS

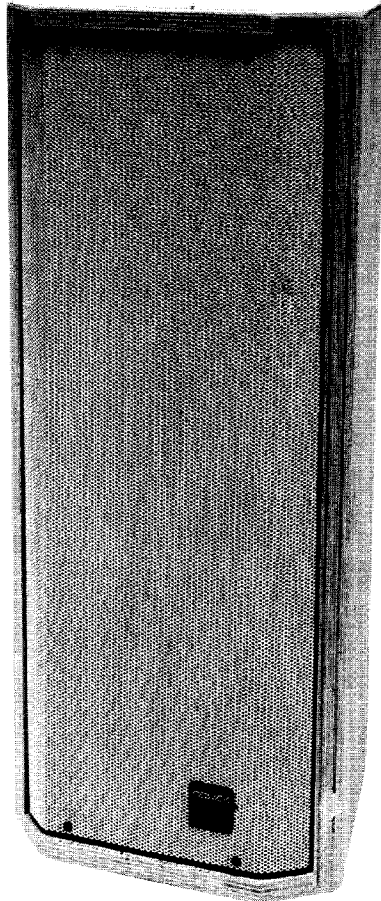

PR™ 2652

Permanent Installation, Trapezoidal Flying Enclosure

SPECIFICATIONS

Frequency Response, 1 meter, on-axis, swept sine in anechoic environment:

100 Hz to 18 kHz ± 3 dB

Low-Frequency Cut-Off (-3 dB point):

100 Hz

Usable Low-Frequency Limit (-10 dB point):

87 Hz

Power Handling:

150 W continuous (34.6 V RMS)
300 W program

Sound Pressure Level, 2.8 V (1 watt) • 1 meter in anechoic environment:

94 dB

Maximum Sound Pressure Level:

116 dB

Radiation Angle Measured at -6 dB Point of Polar Response:

500 Hz to 1.6 kHz:

Horizontal: $127^\circ \pm 17^\circ$
Vertical: $87^\circ \pm 20^\circ$

1.6 kHz to 5 kHz:

Horizontal: $93^\circ \pm 32^\circ$
Vertical: $51^\circ \pm 17^\circ$

5 kHz to 16 kHz:

Horizontal: $45^\circ \pm 3^\circ$
Vertical: $41^\circ \pm 6^\circ$

Directivity Factor, Q (Mean):

9.4

Directivity Index, D_i (Mean)

8.7 dB

Transducer Complement:

Two 6-1/2" woofers
One A/A-2001XT™ compression driver on exponential horn

Box Tuning Frequency:

75 Hz

Harmonic Distortion:

1/100 rated power

2nd harmonic:
100 Hz, 0.4%
1 kHz, 0.4%

3rd harmonic:
100 Hz, 0.44%
1 kHz, 0.56%

1/10 rated power

2nd harmonic:
100 Hz, 0.56%
1 kHz, 1%

3rd harmonic:
100 Hz, 0.44%
1 kHz, 0.8%

Input Connections:

Four-position barrier strip
Neutrik® Speakon®

Impedance:

8 ohms (nominal)
6.1 ohms (minimum)

Crossover Frequency:

3000 Hz

Enclosure Materials & Finish:

Painted Finish:

3/4" 7-ply, Poplar-faced, high-density plywood, gray lacquer paint finish

Natural Finish: (illustrated)

3/4" 9-ply Birch, void-free plywood, ready for finish of user's choice

Dimensions (H x W x D):

24" H x 10" W x 9-1/2" D front
24" H x 5-1/2" W back

Net Weight:

32 lbs.

Mounting:

Four total flying points: 2 load-bearing (1 top/1 bottom), 2 aiming (on back), 1/2" x 13 plug nuts built into enclosure. Use only 1/2" forged shoulder machinery eye bolt, mil spec MS 51937-5.

**PEAVEY**
ARCHITECTURAL ACOUSTICS®

DESCRIPTION

The PR™ 2652 is a two-way system designed primarily for voice projection and high SPL level paging. It is equally suited for side and under balcony fills in auditoriums for live music sound reinforcement. The system consists of two 6-1/2" woofers and one A/A-2001XT compression driver coupled to a conical, high-frequency horn. The cabinet is trapezoidal for easy corner or array placement. It is fitted with four threaded inserts for flying. As an option, these same flying points mate to a tilt or swivel wall mount bracket, the SV 2652™.

This system will perform with excellent versatility in gymnasiums, auditoriums, restaurants, entertainment arenas, places of worship, and anywhere a smaller size but equally efficient sound reinforcement system is required.

DIRECTIVITY

Beamwidth and directivity factors are derived from the -6 dB points from the polar plots, which are measured in a whole-space anechoic environment. These are specifications which provide a reference to the coverage characteristics of the enclosure. These parameters provide insight for proper enclosure placement and installation in the chosen environment. The bending of the components exhibits a desirable beamwidth and directivity factor (figures 3 and 4) suitable for all permanent installations.

FREQUENCY RESPONSE

The frequency response of the PR™ 2652 is measured in an anechoic environment at a distance of one meter using a 2.8-volt swept sine input. The combinations of the low frequency loudspeaker and the constant directivity horn results in a flat response as shown in figure 1.

HARMONIC DISTORTION

Second and third harmonic distortion versus frequency is plotted in figures 5 through 8 for two power levels: 1/10 of rated input power and either 1/100 or rated input power or 1 watt (whichever is greater). Distortion is read from the graph as the difference between the fundamental signal and the desired harmonic. As an example, distortion that is 40 dB down from the fundamental is equivalent to 1%.

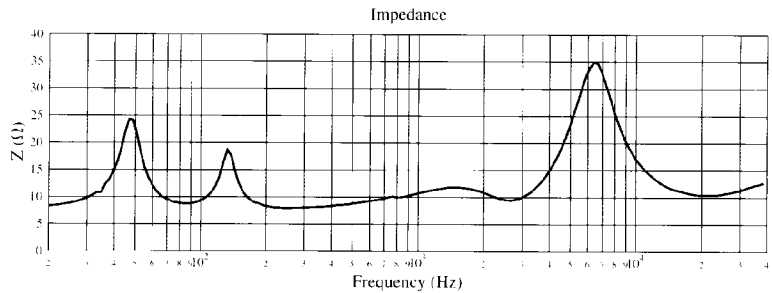
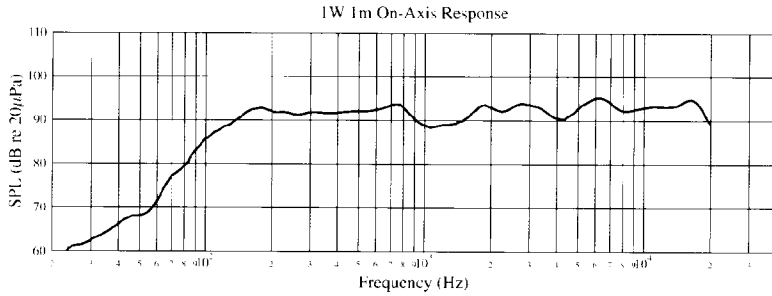

Polar Beamwidth vs Frequency Plot

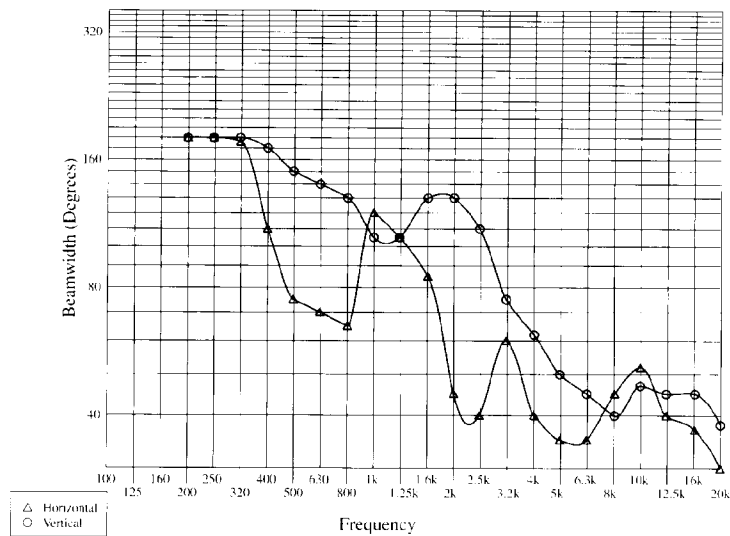

Directivity and Q plots

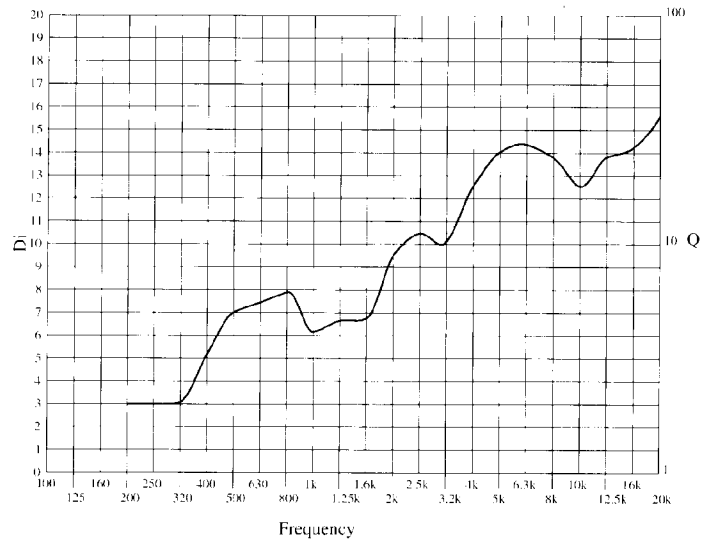

VERTICAL POLAR PATTERNS

6 dB per division

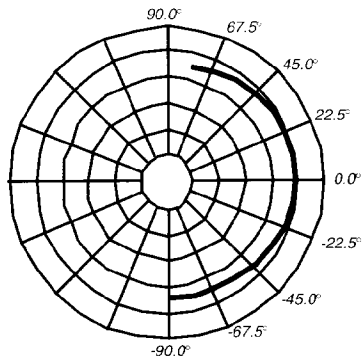

200 Hz

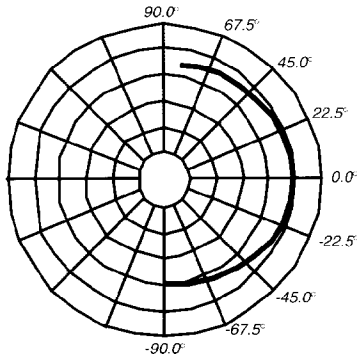

250 Hz

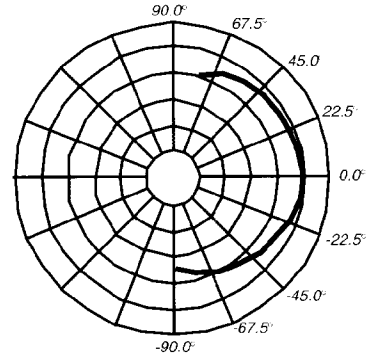

300 Hz

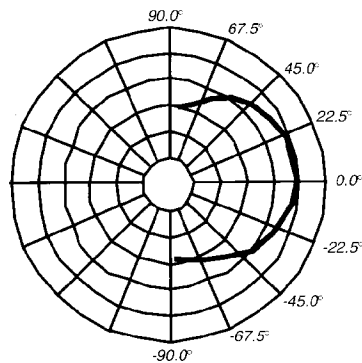

400 Hz

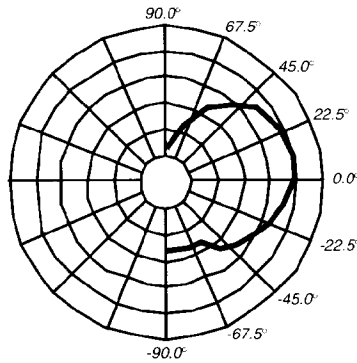

500 Hz

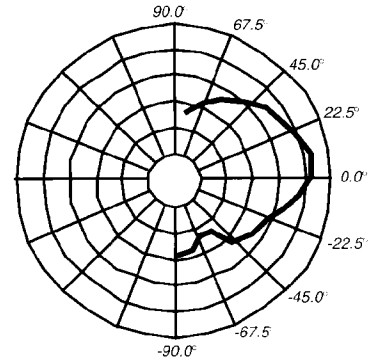

650 Hz

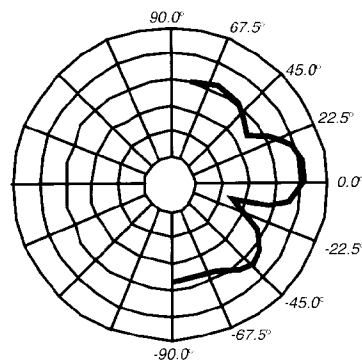

800 Hz

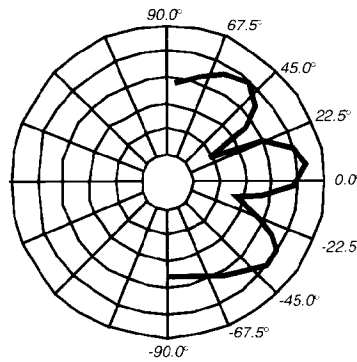

1 kHz

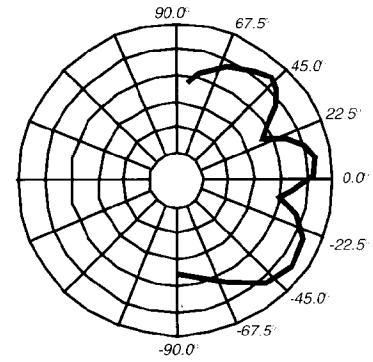

1.25 kHz

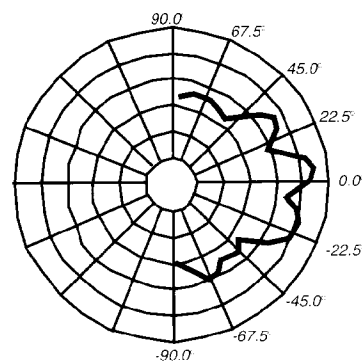

1.6 kHz

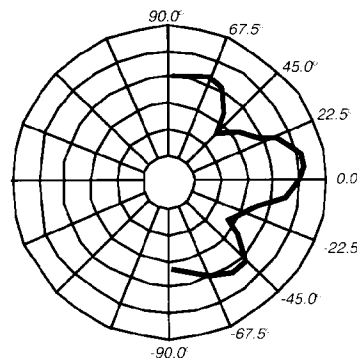

2 kHz

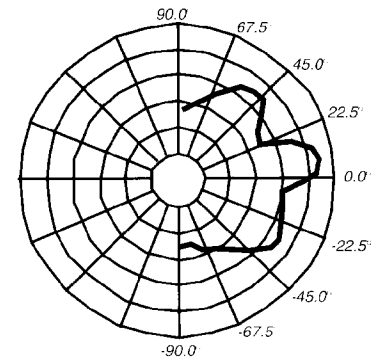

2.5 kHz

HORIZONTAL POLAR PATTERNS

6 dB per division

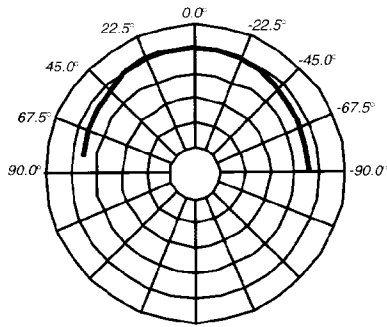

200 Hz

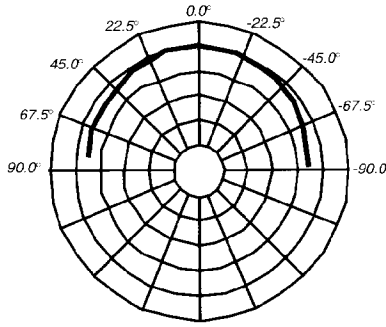

250 Hz

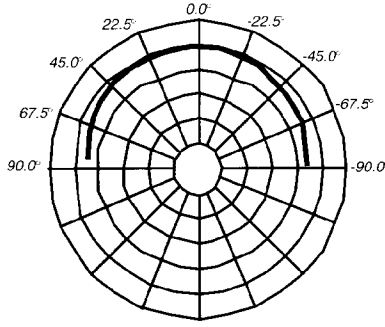

300 Hz

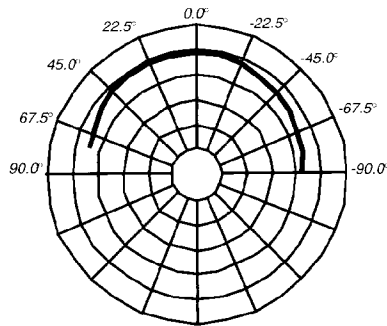

400 Hz

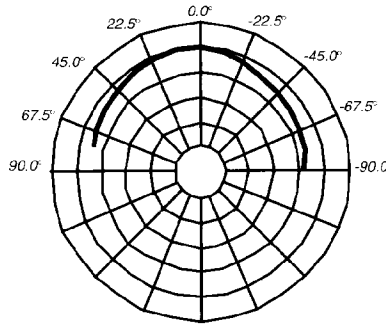

500 Hz

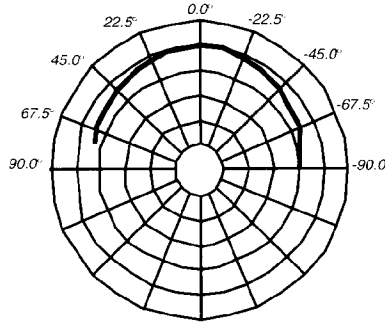

650 Hz

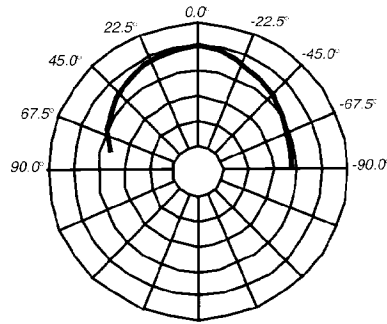

800 Hz

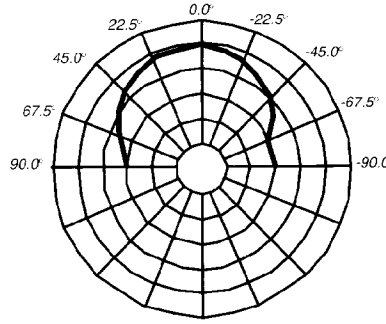

1 kHz

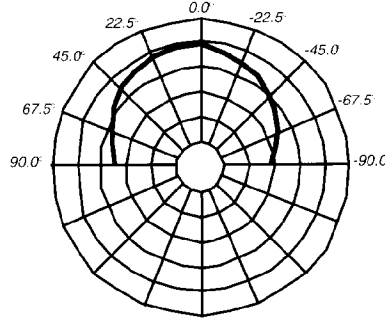

1.25 kHz

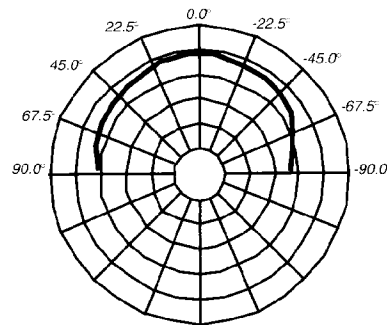

1.6 kHz

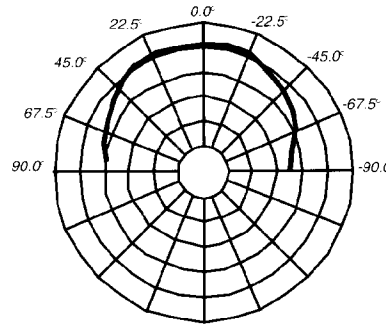

2 kHz

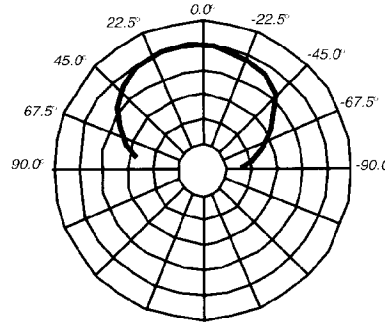

2.5 kHz

HORIZONTAL POLAR PATTERNS

6 dB per division

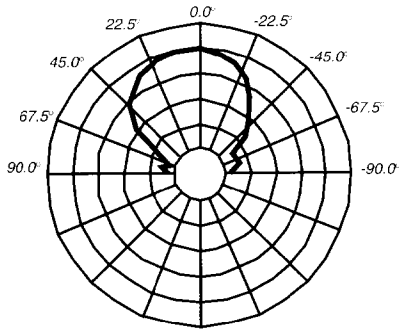

3.1 kHz

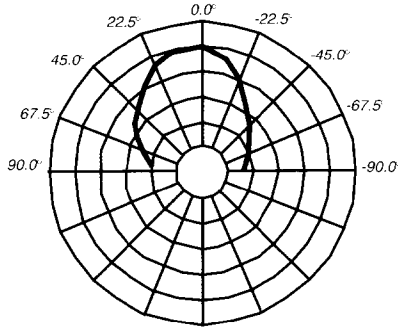

4 kHz

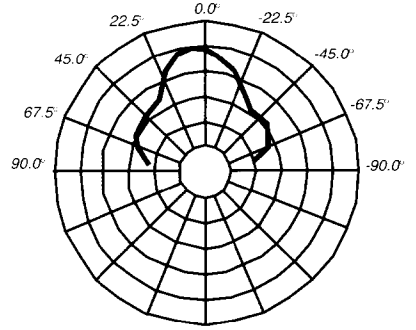

5 kHz

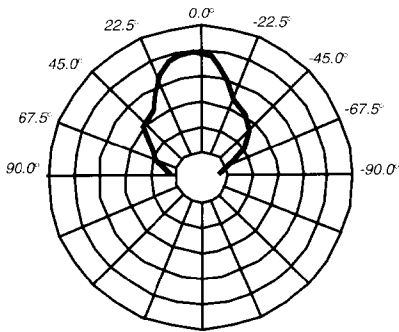

6.3 kHz

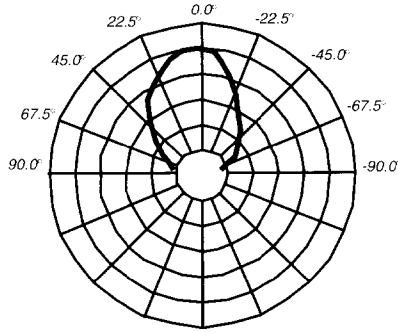

8 kHz

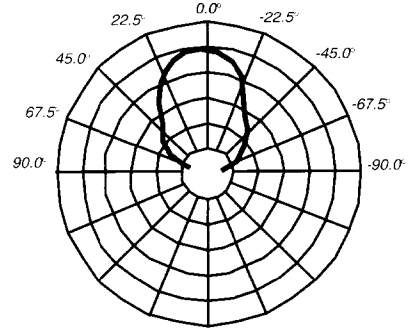

10 kHz

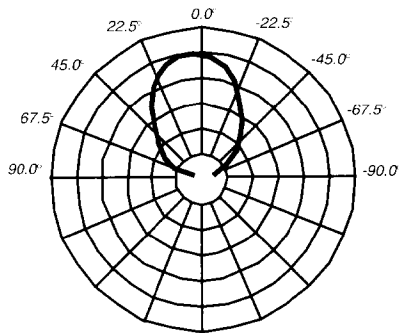

12.5 kHz

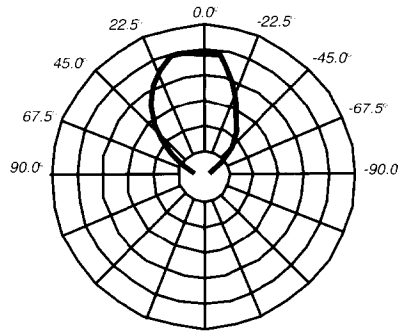

15.8 kHz

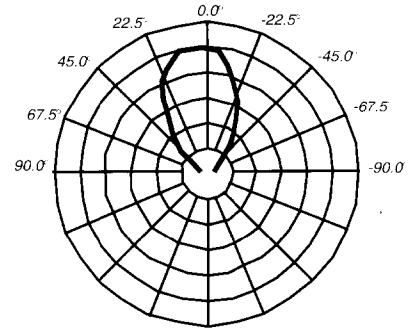

20 kHz

VERTICAL POLAR PATTERNS

6 dB per division

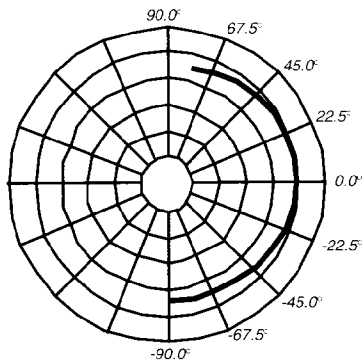

200 Hz

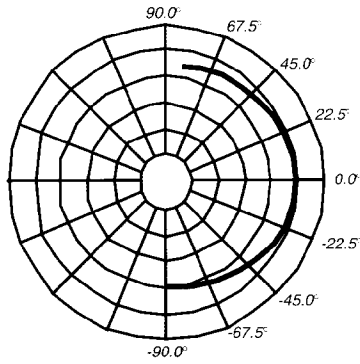

250 Hz

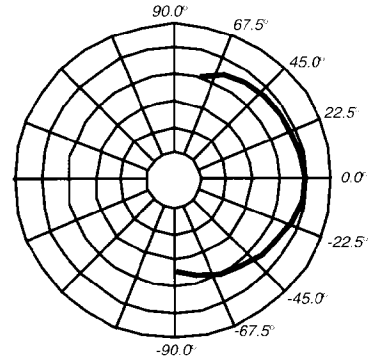

300 Hz

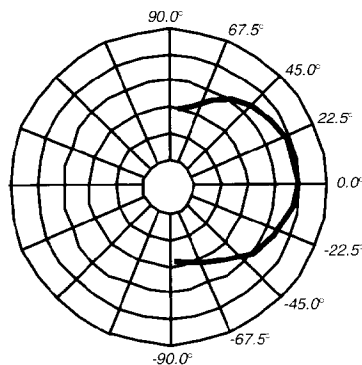

400 Hz

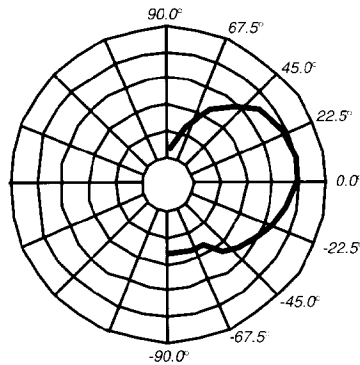

500 Hz

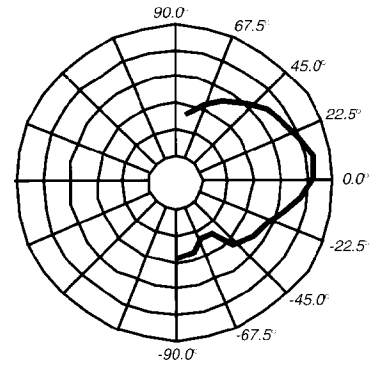

650 Hz

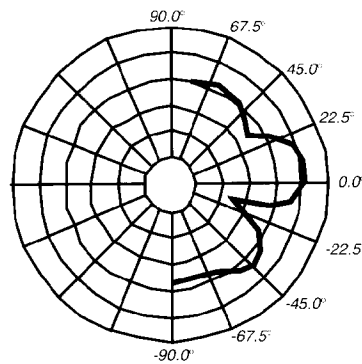

800 Hz

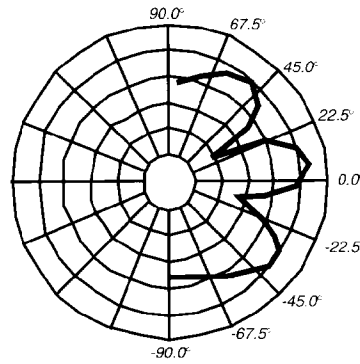

1 kHz

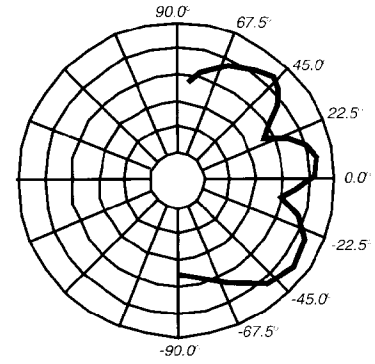

1.25 kHz

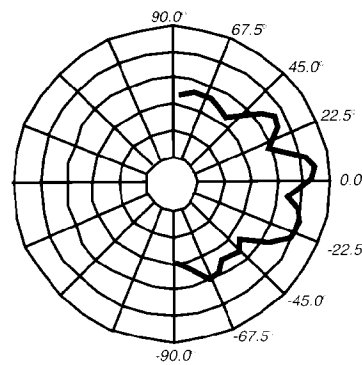

1.6 kHz

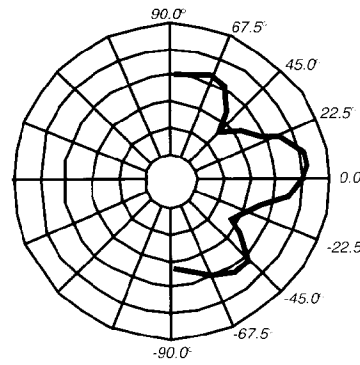

2 kHz

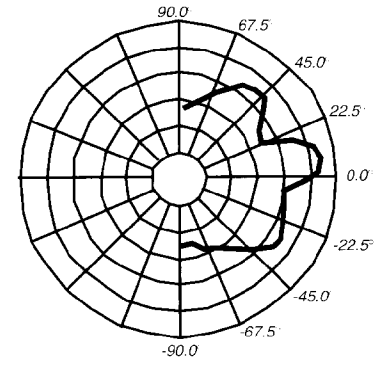

2.5 kHz

VERTICAL POLAR PATTERNS

6 dB per division

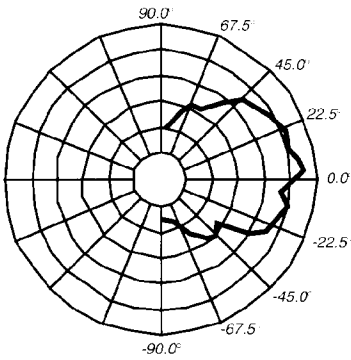

3.1 kHz

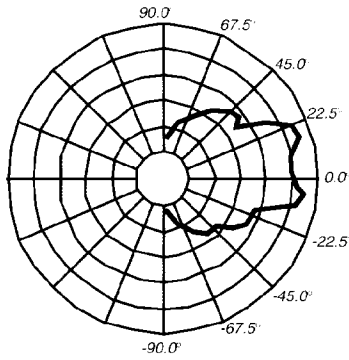

4 kHz

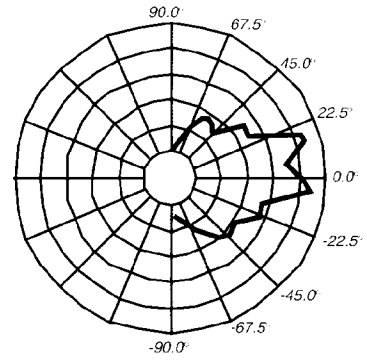

5 kHz

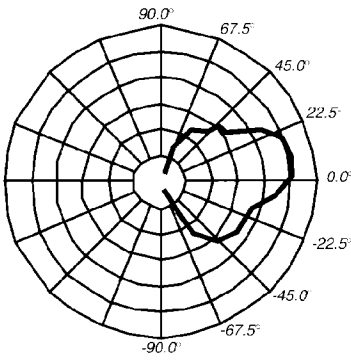

6.3 kHz

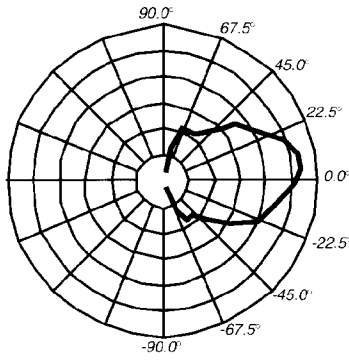

8 kHz

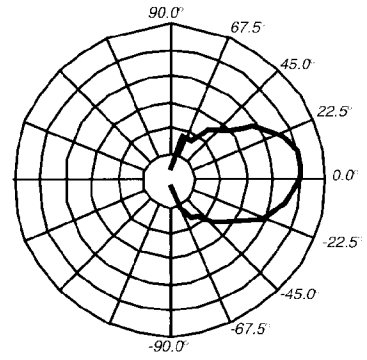

10 kHz

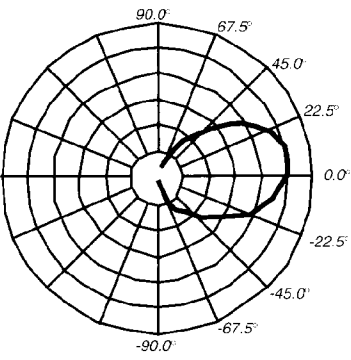

12.6 kHz

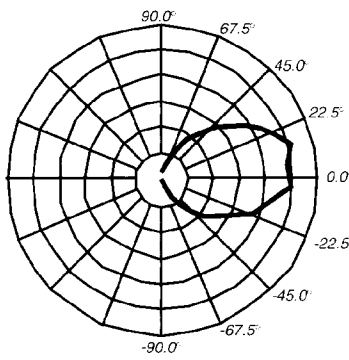

15.8 kHz

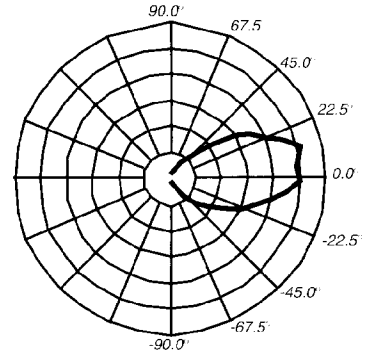

20 kHz



Features and specifications subject to change without notice.

A Division of **Peavey Electronics Corporation**

711 A Street / Meridian, MS 39301 / U.S.A. / (601) 483-5376 / Fax 486-1278
#80304256

©1995

Printed in U.S.A. 12/95