

# S P E C I F I C A T I O N S



## A/A™ 640-2 Constant Directivity Horn

### SPECIFICATIONS

#### Frequency Response, 1 meter on-axis, swept sine in anechoic environment:

500 Hz - 16 kHz (measured with  
A/A™ 4000T Driver)

#### Low Frequency Cut-Off (-3 dB point):

500 Hz

#### Sound Pressure Level, 2.8 V (1 watt) • 1 meter in anechoic environment:

112 dB (measured with A/A 4000T Driver)

#### Radiation Angle, Measure at -6 dB Point of Polar Response:

500 - 1,600 Hz:

Horizontal: 60° ±4°  
Vertical: 71° ±23°

1.6 - 5 kHz:

Horizontal: 62° ±2°  
Vertical: 40° ±4°

5 - 16 kHz:

Horizontal: 56° ±10°  
Vertical: 37° ±3°

#### Directivity Factor, Q (Mean):

500 Hz - 16 kHz, 17.3 ±5.7

#### Directivity Index, D<sub>i</sub> (Mean)

500 Hz - 16 kHz, 12.1 dB ±1.6 dB

#### MOUNTING:

4 aiming points provided near mouth of  
horn. (Primary flying point is on compression  
driver adapter.)

#### Dimensions (H x W x D):

15" H x 28" W x 16" D  
(38.1 cm x 71.1 cm x 40.6 cm)

#### Weight:

16 lbs. (7.2 kg)

#### FEATURES

- 2" throat
- Flying points
- 60° x 40° coverage
- Fiberglass reinforcement

#### DESCRIPTION

The A/A™ 640-2 is a constant-directivity horn designed for high-quality permanent installation sound reinforcement applications. It has a 2" throat and is recommended for use with the A/A™ 4000T compression driver. A well-behaved device should maintain good control of its dispersion characteristics. This is indeed the case with this horn, having coverage angles of 60° horizontal and 40° vertical. Driver loading is maintained to below 500 Hz

for maximum bandwidth performance. The A/A 640-2 is very unique in its construction. Fiberglass reinforcement gives superior strength with resin transfer technology. Flying points are an integral part of the A/A 640-2, so suspension is no problem.

#### DIRECTIVITY

Beamwidth and directivity factors are derived from the -6 dB points from the polar plots, which are measured in a whole-space anechoic environment. These are specifications which provide a reference to the coverage characteristics of the horn. These parameters provide insight for proper enclosure placement and installation in the chosen environment. The A/A 640-2 exhibits a desirable beamwidth and directivity factor suitable for all high-level sound reinforcement applications.

**PEAVEY**  
ARCHITECTURAL ACOUSTICS®

# HORIZONTAL POLAR PATTERNS

6 dB per division

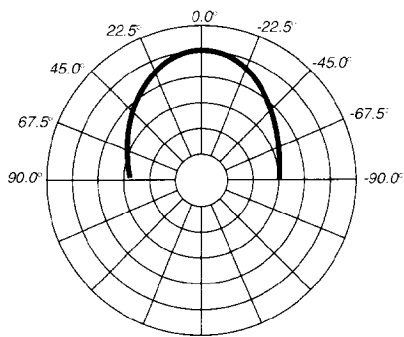

400 HZ

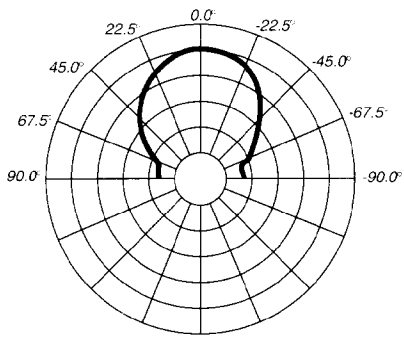

500 HZ

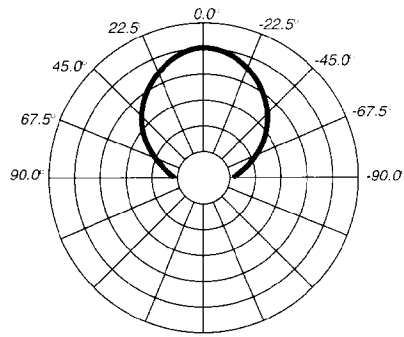

630 HZ

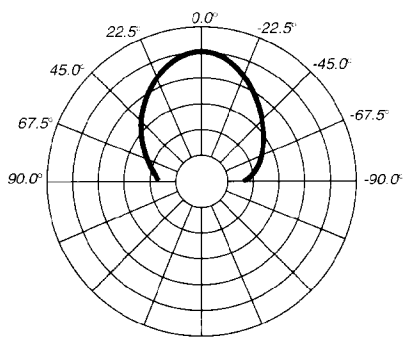

800 HZ

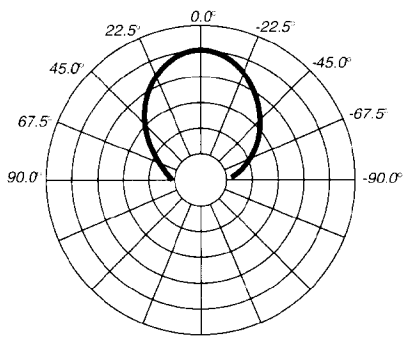

1 K

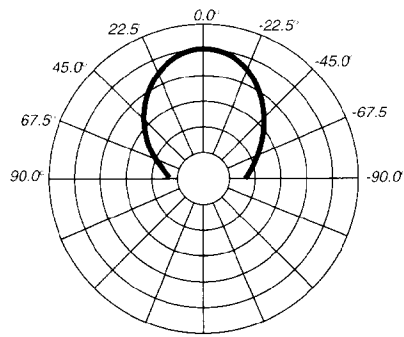

1.25 K

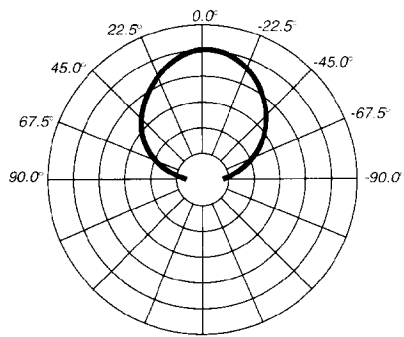

1.6 K

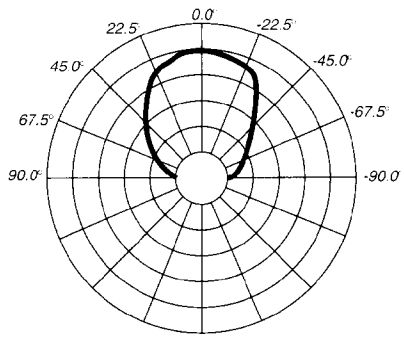

2 K

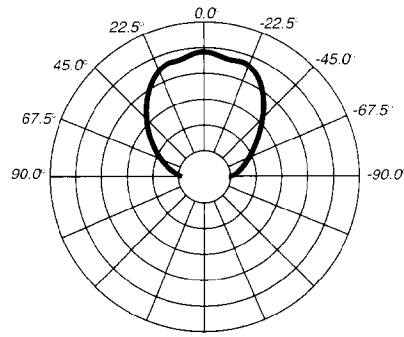

2.5 K

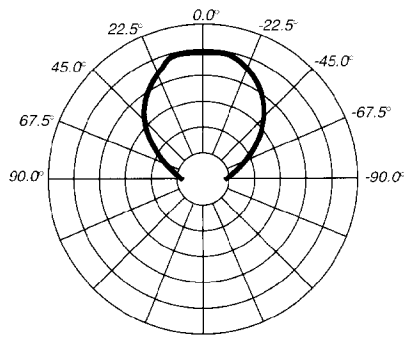

3.15 K

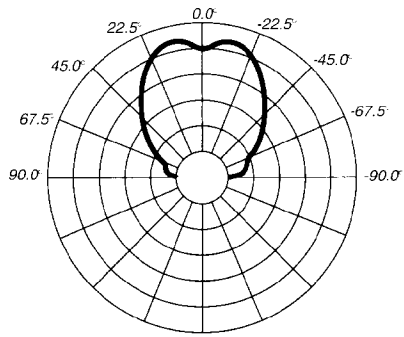

4 K

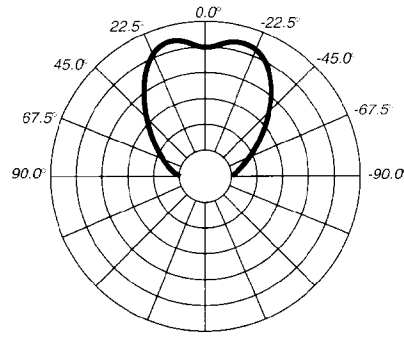

5 K

# HORIZONTAL POLAR PATTERNS

6 dB per division

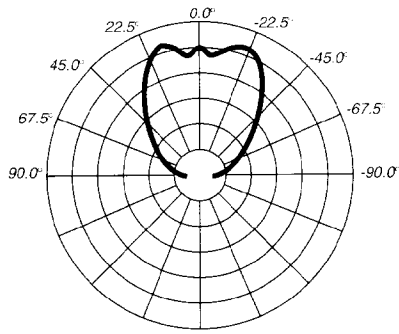

6.3 K

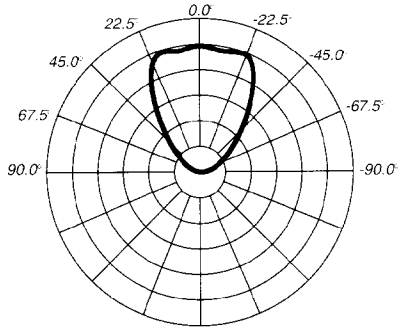

8 K

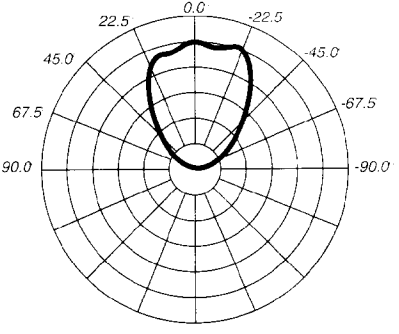

10 K

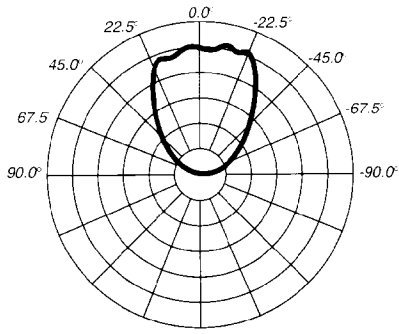

12.5 K

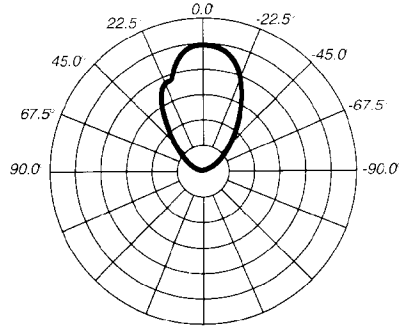

16 K

# VERTICAL POLAR PATTERNS

6 dB per division

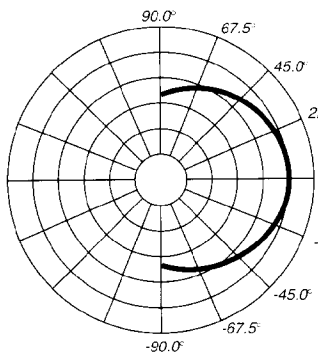

400 HZ

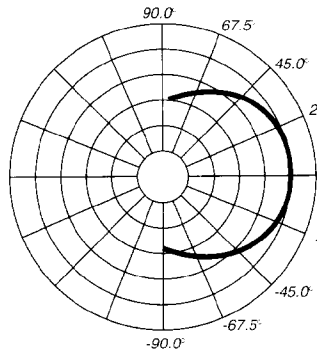

500 HZ

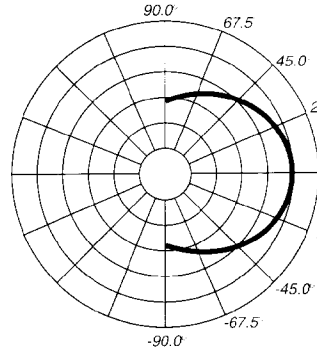

630 HZ

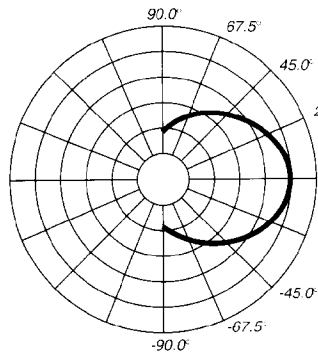

800 HZ

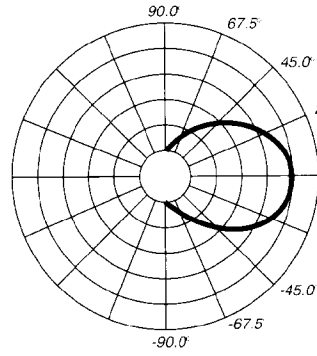

1 K

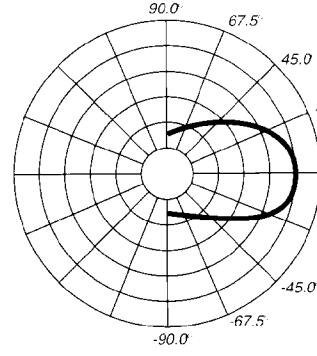

1.25 K

# VERTICAL POLAR PATTERNS

6 dB per division

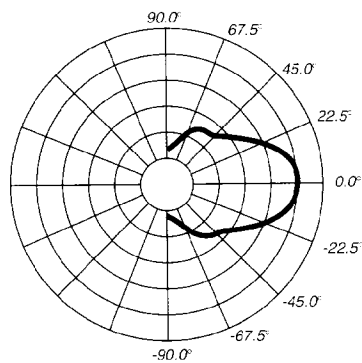

1.6 K

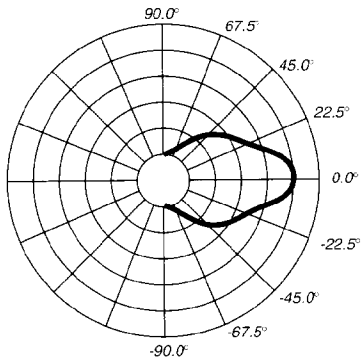

2 K

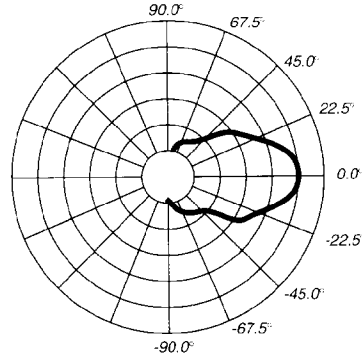

2.5 K

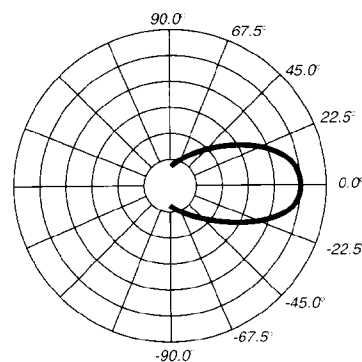

3.15 K

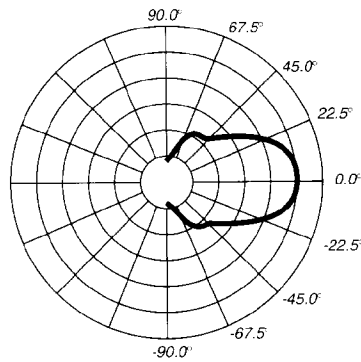

4 K

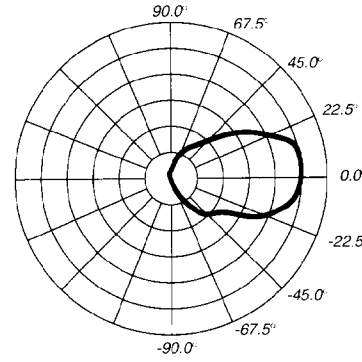

5 K

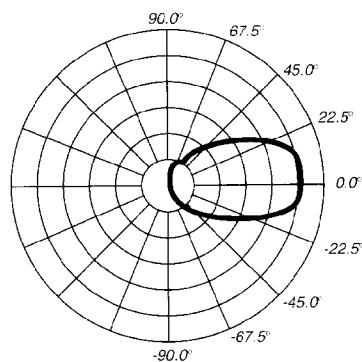

6.3 K

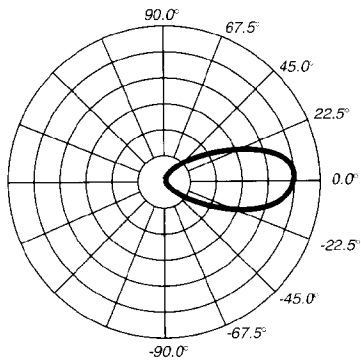

8 K

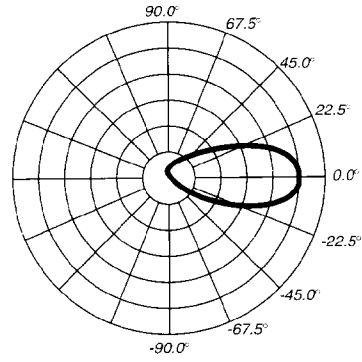

10 K

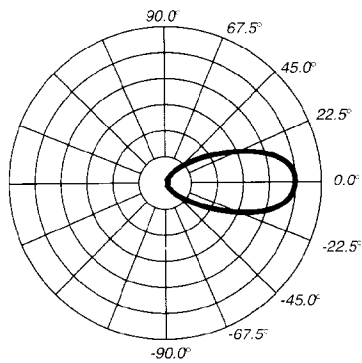

12.5 K

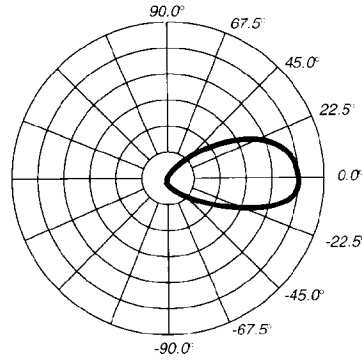

16 K



Features and specifications subject to change without notice.

A Division of **Peavey Electronics Corporation**  
711 A Street / Meridian, MS 39301 / U.S.A. / (601) 483-5376 / Fax 486-1278  
#80301996

©1995

Printed in U.S.A. 3/95

### FREQUENCY RESPONSE

This measurement is useful in determining how accurately a given enclosure reproduces an input signal. The frequency response of the A/A™ 640-2 is measured at 1 meter using a 2.8 volt swept-sine input. As shown in Figure 1, the selected drivers in the A/A 640-2 combine to give a smooth frequency response from 500 Hz to 16 kHz.

### ARCHITECTURAL & ENGINEERING SPECIFICATIONS

The loudspeaker system shall have an operating bandwidth of 500 Hz to 16 kHz. The output level shall be 112 dB when measured at a distance of one meter with an input of one watt while using an A/A™ 4000T compression driver. The nominal radiation geometry shall be 60 degrees in the horizontal plane and 40 degrees in the vertical plane. The outside dimensions shall be 15 inches high by 28 inches wide by 16 inches deep. The weight shall be 16 lbs. The loudspeaker system shall be a Peavey Architectural Acoustics model A/A™ 640-2.

### ONE YEAR LIMITED WARRANTY

**NOTE:** For details, refer to the warranty statement. Copies of this statement may be obtained by contacting Peavey Electronics Corporation, P.O. Box 2898, Meridian, Mississippi 39302-2898.

Frequency Response, Fig. 1

