

# S P E C I F I C A T I O N S

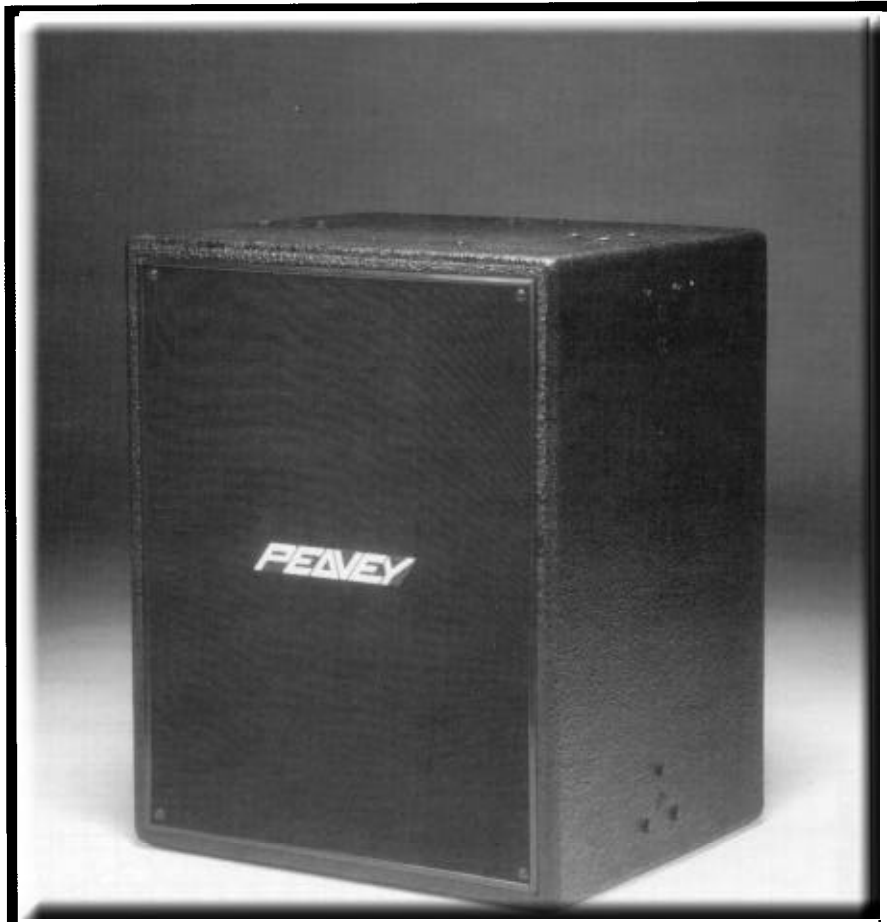

## ER™ 1500 Speaker System

### SPECIFICATIONS

**Frequency Response, 1 meter on-axis, swept sine in anechoic environment:**  
55 -3,500 Hz

**Low Frequency Cut-Off (-3 dB point):**  
55 Hz

**Useable Low Frequency Limit (-10 dB point):**  
45 Hz

**Power Handling:**  
350 W continuous (52.9 V RMS)  
700 W program

**Sound Pressure Level, 2.8 V (1 watt) • 1 meter in anechoic environment:**  
100 dB

**Maximum Sound Pressure Level:**  
123 dB

**Radiation Angle Measure at -6 dB Point of Polar Response:**  
315 - 1,000 Hz:  
110° ±24°  
1.0 - 3.15 kHz:  
56° ±19°

**Directivity Factor, Q (Mean):**  
315 Hz - 3.15 kHz: 11.9 dB

**Directivity Index, D<sub>i</sub> (Mean):**  
315 Hz - 3.15 kHz: 9.2 dB

**Transducer Complement:**  
One A/A 1558 DT woofer

**Box Tuning Frequency:**  
57 Hz

### Harmonic Distortion:

1/100 rated power  
2nd harmonic:  
100 Hz - 1.0%  
1,000 Hz - 0.6%  
3rd harmonic:  
100 Hz - 0.6%  
1,000 Hz - 0.4%  
1/10 rated power  
2nd harmonic:  
100 Hz - 2.8%  
1,000 Hz - 0.9%  
3rd harmonic:  
100 Hz - 1.4%  
1,000 Hz - 0.6%

### Input Connections:

Screw terminals on barrier strip

### Impedance:

8 ohms (nominal)  
6.8 ohms (minimum)

### Enclosure Materials & Finish:

3/4" plywood with 10 ga. steel reinforcement and protective metal grille, utility black paint with cosmetic black cloth grille

### MOUNTING:

10 flying points (4 horizontal, 4 vertical 2 aiming/tilt). Before attempting to suspend this speaker, consult a certified structural engineer. Speaker can fall from improper suspension, resulting in serious injury and property damage. Other enclosures may be suspended below one ER-1500. However, the combined weight of additional enclosures and all cables, clamps, and other hardware must not exceed 280 lbs. The ER-1500 weighs 70 lbs. and the maximum combined weight suspended from the uppermost mounting bracket assemblies must not exceed 350 lbs. Maximum enclosure angle 45°. Use only 1/2" forged shoulder machinery eyebolt, mil spec. MS51937-5; all associated rigging is the responsibility of others.

### Dimensions (H x W x D):

25.000" H x 20.250" W x 17.813" D  
(63.5 cm x 51.4 cm x 45.2 cm)

### Net Weight:

70 lbs. (31.8 kg)

**PEAVEY**  
ARCHITECTURAL ACOUSTICS®

## FEATURES

- Protective metal grille
- Cosmetic cloth grille
- Reinforced flying points top and bottom
- High output driver
- Barrier strip screw terminals

## DESCRIPTION

The ER™ 1500 is a direct-radiating bass speaker system designed for high-performance permanent installation applications. It is loaded with an A/A 1558-DT driver. This driver provides high SPL output with minimum distortion. Flying points are an integral part of the ER 1500. Ten-gauge steel bracing is used at every flying point to fully distribute the load throughout the enclosure. This enables other enclosures or horns to be flown from the bottom of the ER 1500. A sturdy metal grille protects the driver should any object get too close. A black cloth grille covers the entire front of the enclosure for cosmetic appeal. Input is provided via barrier strip screw terminals. There are two positive and two negative terminals, which are internally paralleled. This should greatly aid in final wiring of enclosures to be paralleled. The ER 1500 has an output of 100 dB SPL (1 W, 1 m) and will handle 350 W continuous/700 W program. Frequency response is from 55 Hz to 3.5 kHz.

## DIRECTIVITY

Beamwidth and directivity factors are derived from the -6 dB points from the polar plots, which are measured in a whole-space anechoic environment. These are specifications which provide a reference to the coverage characteristics of the enclosure. These parameters provide insight for proper enclosure placement and installation in the chosen environment. The ER™ 1500 exhibits a desirable beamwidth and directivity factor suitable for all high-level sound reinforcement applications.

## FREQUENCY RESPONSE

This measurement is useful in determining how accurately a given enclosure reproduces an input signal. The frequency response of the ER™ 1500 is measured at 1 meter using a 2.8 volt swept sine input. As shown in Figure 1, the selected drivers in the ER 1500 combine to give a smooth frequency response from 55 Hz to 3.5 kHz.

Frequency Response

Fig. 1

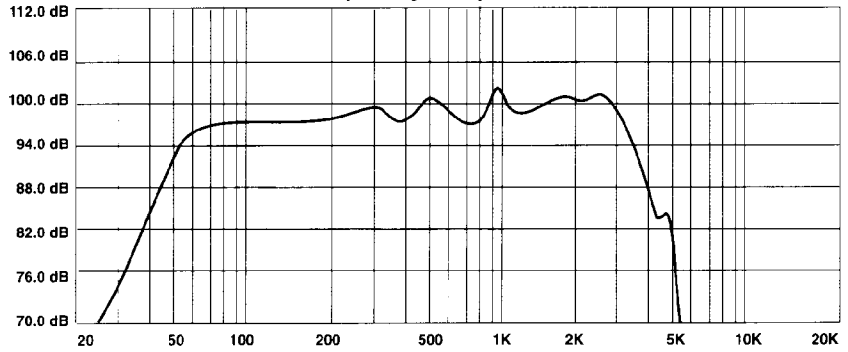

Impedance

Fig. 2

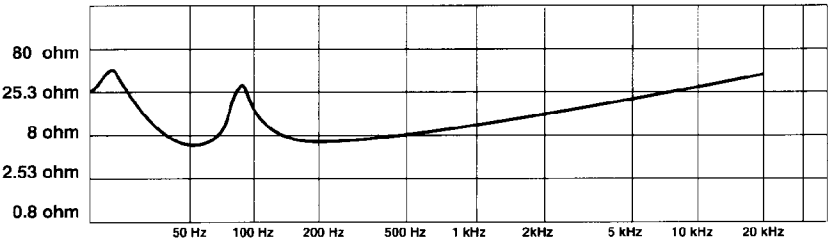

Fig. 3

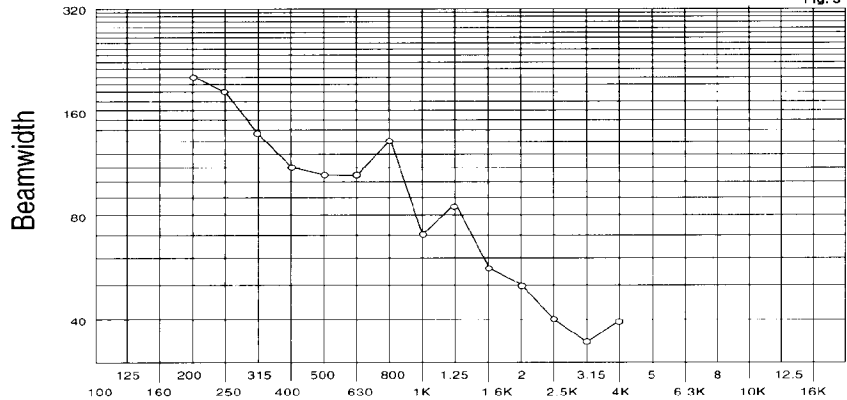
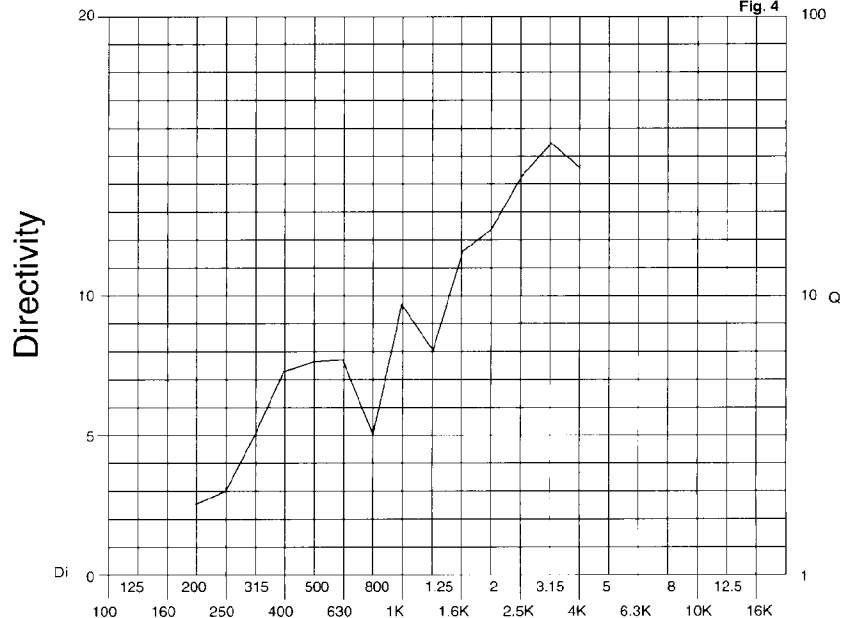

Fig. 4



## POWER HANDLING

There are many different approaches to power handling ratings. Peavey rates this speaker system's power handling using a modified form of the AES Standard 2-1984. Utilizing audio band (20 Hz - 20 kHz) pink noise with peaks over four times the RMS level, this strenuous test signal assures the user that every portion of this system can withstand today's high-technology music. The test signal contains large amounts of very low frequency energy, effectively simulating the frequency content of live music situations. The full measure of high frequencies in the test signal allow for exposure of the speaker system to synthesized tone that may extend beyond audibility. This rating is contingent on having a minimum 3 dB of amplifier headroom available.

## ARCHITECTURAL & ENGINEERING SPECIFICATIONS

The loudspeaker system shall have an operating bandwidth of 55 Hz to 3.5 kHz. The output level shall be 100 dB when measured at a distance of one meter with an input of one watt. The nominal impedance shall be 8 ohms. The continuous power handling shall be 350 watts, with maximum program power of 700 watts and minimum amplifier headroom of 3 dB. The nominal radiation geometry shall be 90 degrees in the horizontal plane and 90 degrees in the vertical plane. The outside dimensions shall be 25.000 inches high by 20.250 inches wide by 17.813 inches deep. The weight shall be 70 lbs. The loudspeaker system shall be a Peavey model ER™ 1500.

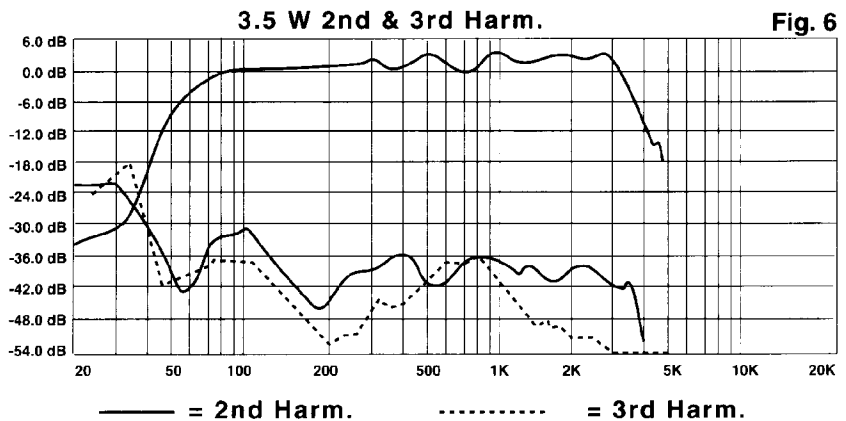
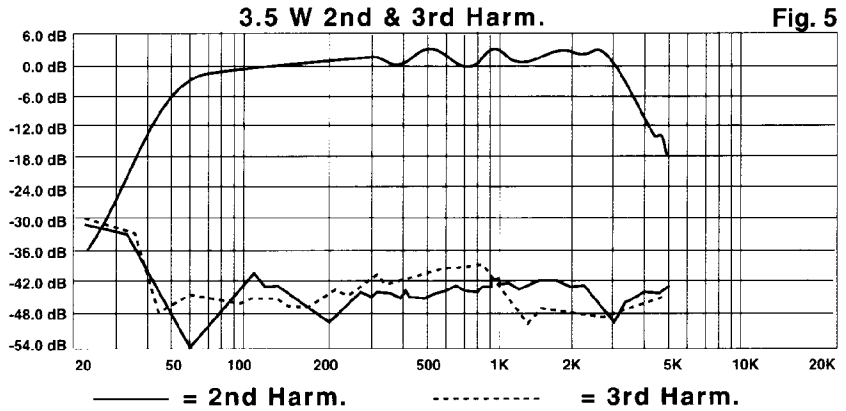

## POWER HANDLING

There are many different approaches to power handling ratings. Peavey rates this speaker system's power handling using a modified form of the AES Standard 2-1984. Utilizing audio band (20 Hz - 20 kHz) pink noise with peaks over four times the RMS level, this strenuous test signal assures the user that every portion of this system can withstand today's high-technology music. The test signal contains large amounts of very low frequency energy, effectively simulating the frequency content of live music situations. The full measure of high frequencies in the test signal allow for exposure of the speaker system to synthesized tone that may extend beyond audibility. This rating is contingent on having a minimum 3 dB of amplifier headroom available.

## ARCHITECTURAL & ENGINEERING SPECIFICATIONS

The loudspeaker system shall have an operating bandwidth of 55 Hz to 3.5 kHz. The output level shall be 100 dB when measured at a distance of one meter with an input of one watt. The nominal impedance shall be 8 ohms. The continuous power handling shall be 350 watts, with maximum program power of 700 watts and minimum amplifier headroom of 3 dB. The nominal radiation geometry shall be 90 degrees in the horizontal plane and 90 degrees in the vertical plane. The outside dimensions shall be 25.000 inches high by 20.250 inches wide by 17.813 inches deep. The weight shall be 70 lbs. The loudspeaker system shall be a Peavey model ER™ 1500.

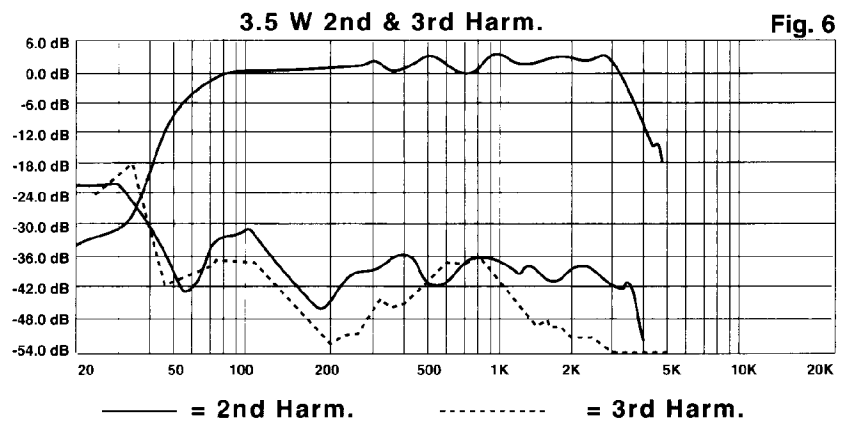
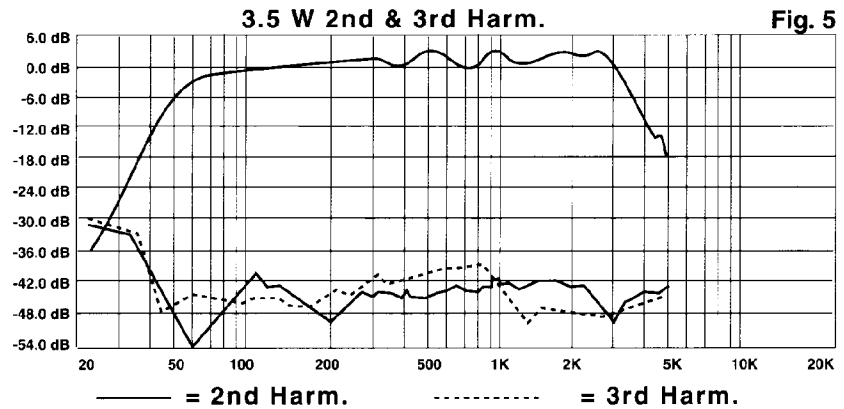

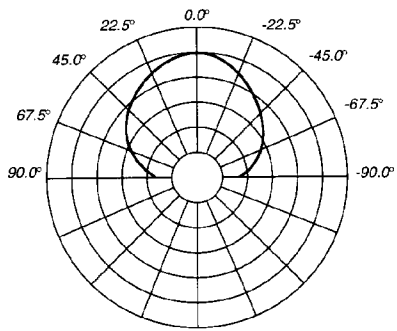

1 kHz

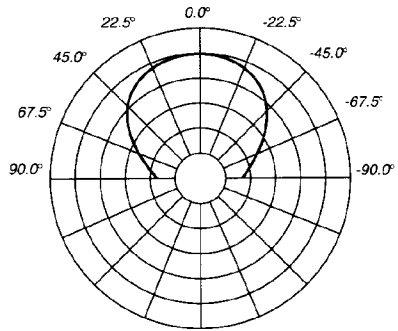

1.25 kHz

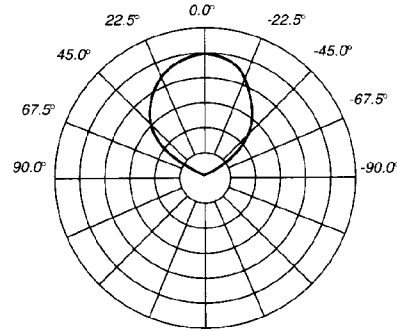

1.6 kHz

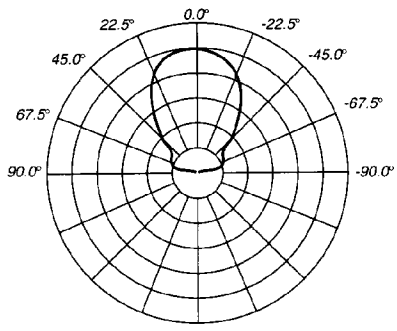

2 kHz

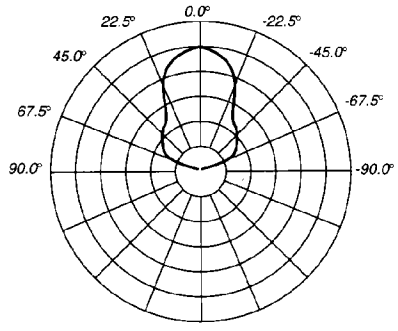

2.5 kHz

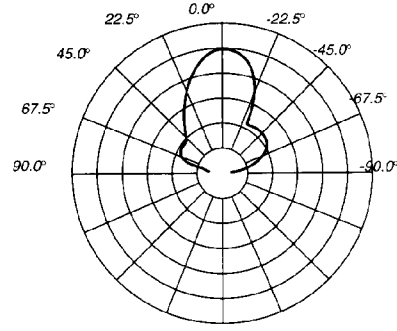

3.15 kHz

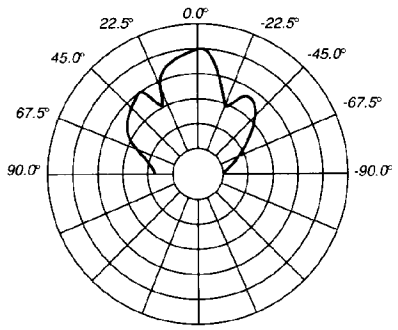

4 kHz

## LIMITED WARRANTY

Peavey Electronics Corporation warrants to the original purchaser of this new Architectural Acoustics product that it is free from defects in material and workmanship. If within one (1) year from date of purchase a properly installed product proves to be defective and Peavey is notified, Peavey will repair or replace it at no charge. (Note: Batteries and patch cords not covered.) "Original purchaser" means the customer for whom the product is originally installed.

Damage resulting from improper installation, interconnection of a unit or system of another manufacturer, accident or unreasonable use, neglect or any other cause not arising from defects in material, and workmanship is not covered by this warranty. The warranty is valid only as to products purchased and installed in the United States.

**THIS LIMITED WARRANTY IS IN LIEU OF ANY AND ALL WARRANTIES, EXPRESSED OR IMPLIED, INCLUDING THE IMPLIED WARRANTIES OF MERCHANTABILITY AND FITNESS FOR A PARTICULAR USE. UNDER NO CIRCUMSTANCES WILL PEAVEY BE LIABLE FOR ANY LOST PROFITS, LOST SAVINGS, INCIDENTAL DAMAGES OR CONSEQUENTIAL DAMAGES ARISING OUT OF THE USE OR INABILITY TO USE THE PRODUCT, EVEN IF PEAVEY HAS BEEN ADVISED OF THE POSSIBILITY OF SUCH DAMAGE. THIS LIMITED WARRANTY IS THE ONLY EXPRESSED WARRANTY ON THIS PRODUCT, AND NO OTHER STATEMENT, REPRESENTATION, WARRANTY, OR AGREEMENT BY ANY PERSON SHALL BE VALID OR BINDING UPON PEAVEY.**

Peavey's liability to the original purchaser for damages for any cause whatsoever and regardless of the form of action, is limited to the actual damages up to the greater of Five Hundred Dollars (\$500) or an amount equal to the purchase price of the product that caused the damage or that is the subject of or is directly related to the cause of action. This limitation of liability will not apply to claims for personal injury or damage to real property or tangible personal property allegedly caused by Peavey's negligence. For information on service under this warranty, call a Peavey customer service representative at (601) 483-5376.



Features and specifications subject to change without notice.

A Division Of Peavey Electronics Corporation 711 A Street / Meridian, MS 39301 / U.S.A. / (601) 483-5376 / Telex: 504115 / Fax: 486-1278

©1994

#80301995

Printed in U.S.A. 2/94