

OPERATING INSTRUCTIONS

MATM 212

3 Channel

Mixer Power Amplifier



CAUTION: TO PREVENT ELECTRICAL SHOCK OR FIRE HAZARD, DO NOT EXPOSE THIS APPLIANCE TO RAIN OR MOISTURE. BEFORE USING THIS APPLIANCE, READ BACK COVER FOR FURTHER WARNINGS.

DESCRIPTION:

The Architectural Acoustics MA™ 212 is a high quality mixer/amplifier with three separate input channels. Channel 1 and program feature bass and treble controls along with contour (special defeatable equalization). Each channel includes a level control.

The MA 212 provides unmatched application flexibility with an array of optional plug-in modules, allowing each system to be custom-tailored for specialized installations. Input modules may be loaded in as required at the two input ports for varying sound reinforcement applications, number of input channels, special functions, etc.

The program input includes a separate level control and is totally separate from the other two channels. External signals may be patched in at this point as a system auxiliary input or the "third" channel. Signals appearing at this input are routed directly to the master summing amplifier stage and are mixed with signals from the other two chan-

nels. Systems requiring a single input may use the program channel and the purchase of an input module may not be necessary. The program input is routed through the bass and treble controls.

The power section delivers 12 watts into a broad load impedance range including twenty-five and seventy volt line output operation. A smoke tinted security cover has been provided with a "snap-on" feature to guard against accidental or malicious alteration of system calibration.

FEATURES:

- 3 channel mixer/power amplifier system
- 40 Hz - 20 kHz frequency response
- Dedicated program input
- Contour switch (special equalization)
- Bass and Treble controls
- Plug in module capability
- Smoke-tinted security cover

FRONT PANEL

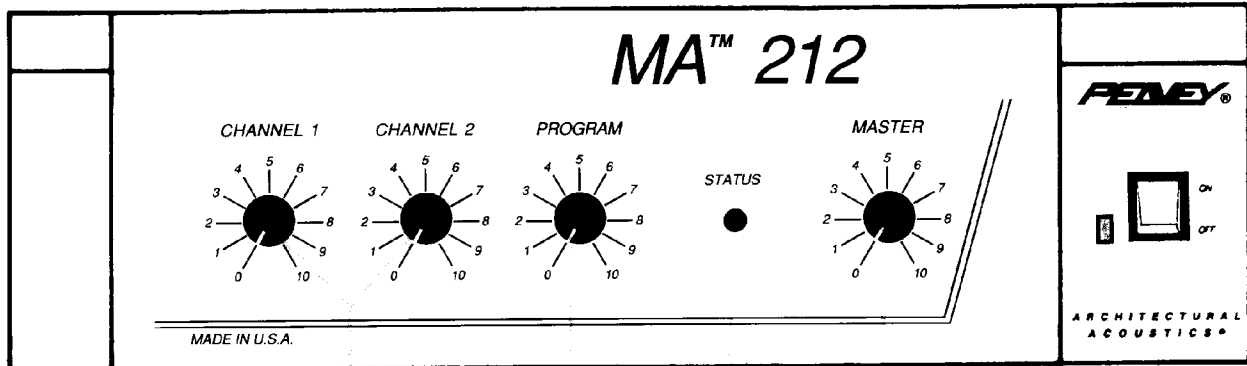

1

2

3

4

5

6

Channel Level Control (1)

Controls the signal level at the channel input.

Program Level Control (2)

Controls the signal level at the program input.

Status LED (3)

Indicates output level from the master mixing stage. Bi-color illumination capability indicates signal activity (green) and 2 dB below clipping (red).

Master (4)

Controls the overall volume level of the system.

Power On LED (5)

Indicates when AC power is being supplied to the unit.

Power Switch (6)

Depress to "on" position to turn on.

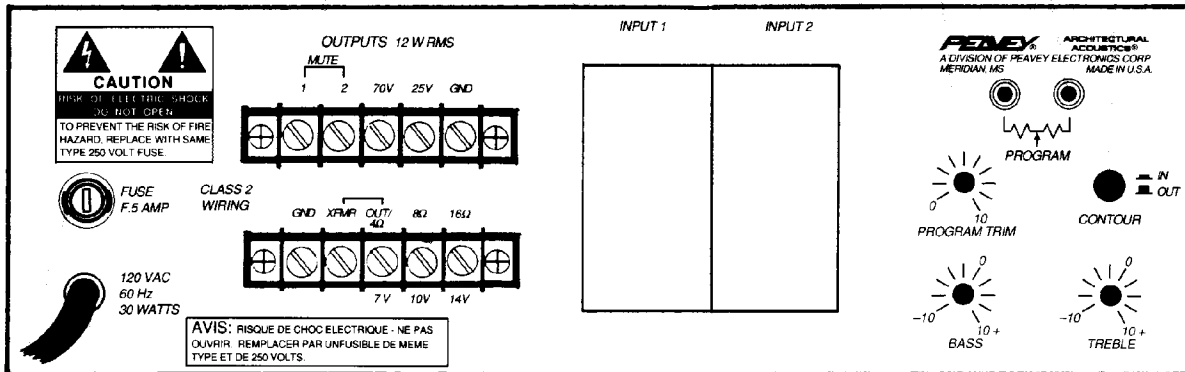

Mute (7)

Plug-in modules are available with muting function. The mute line may be activated with an external switch at this point.

Outputs (8)

A direct output, as well as several Autoformer outputs, are provided to allow the proper interface between the amplifier and the speaker system. The direct output allows direct connection to a 4 ohm speaker system. To use this output, disconnect the jumper between the OUT terminal and the XFMR terminal. Connect the speaker (or speakers) from the GND terminal to the out terminal.

8 ohm, 16 ohm, 25 volt and 70 volt outputs are also provided. To use these outputs, the jumper between OUT and XFMR must be installed. For 8 ohm speaker systems, connect between the GND terminal and the 8 ohm terminal. For use with 16 ohm speaker systems, connect between the GND terminal and the 16 ohm/25V terminal.

25V and 70V outputs are also provided for "constant voltage" speaker distribution systems. The 25V output connection is between the GND terminal to the 16 ohm/25V terminal.

Module Input Ports (9)

Accepts plug-in modules for both channels. Modules are optional and should be selected by installation requirement. **NOTE:** All modules will function in either of the two ports.

Program In (10)

Accepts signals from other sources such as another mixer or mixer amplifier. Signal level at this input is controlled by the Program level control and is fed to the Master output.

The program in may be regarded as channel "three" without plug-in module capability. **NOTE:** This input is muted whenever the mute line is grounded.

Program Trim (11)

Adjusts the program input sensitivity pre (before the) program level control.

Low EQ Control (Bass) (12)

Active equalization control that adjusts the low frequency response. Clockwise rotation boosts lows while counterclockwise rotation provides a cut (reduction) of the low frequencies (± 10 dB). (Functional on channel 1 and program.)

High EQ Control (Treble) (13)

Active equalization control that adjusts the high frequency response. Clockwise rotation boosts highs while counterclockwise rotation provides a cut (reduction) of the high frequencies (± 10 dB). (Functional on channel 1 and program.)

Contour Switch (14)

The "in" position of this switch provides 6 dB boost at 100 Hz and 6 dB boost at 10 kHz. The "out" position removes boost from the system. (Functional on channel 1 and program.)

Fuse (15)

Replace with the same size and rating.

Power Cord (16)

Connect to 120V AC power source.

Block Diagram

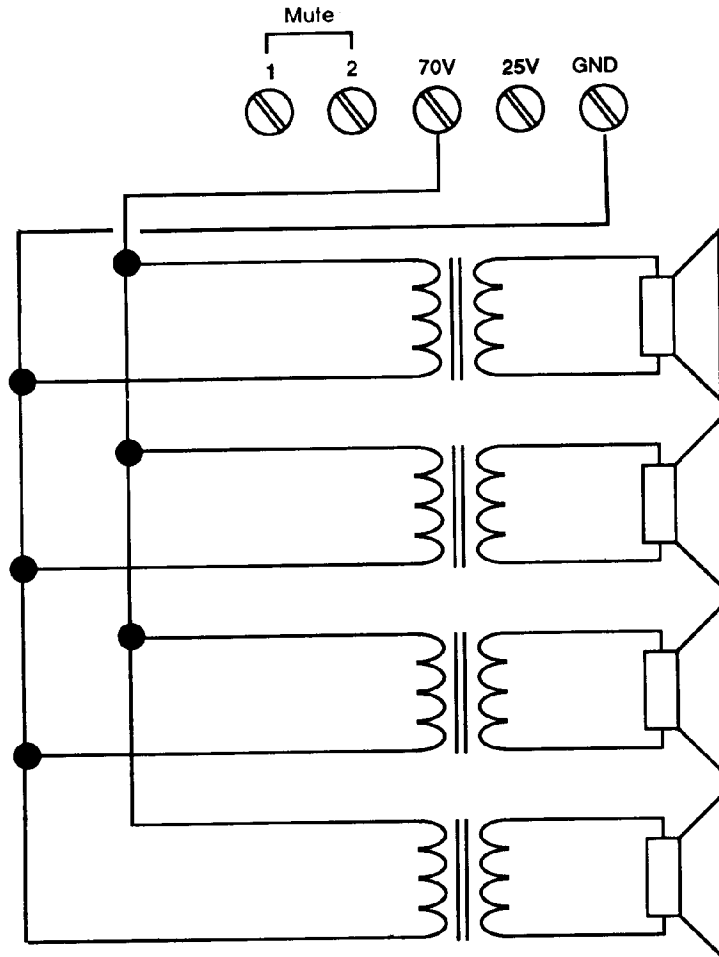
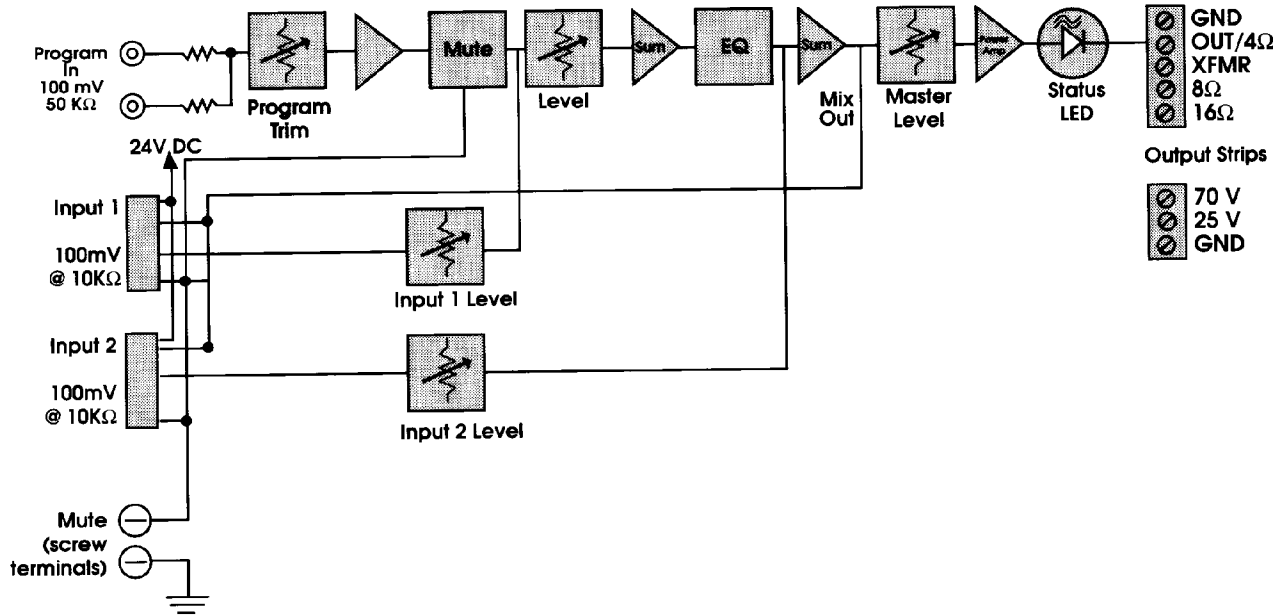

70 V "Constant Voltage" Distribution System

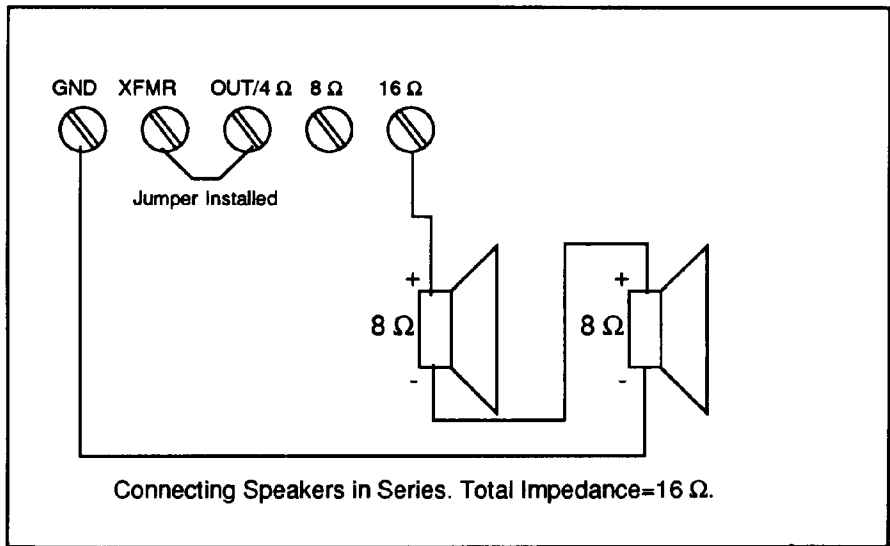
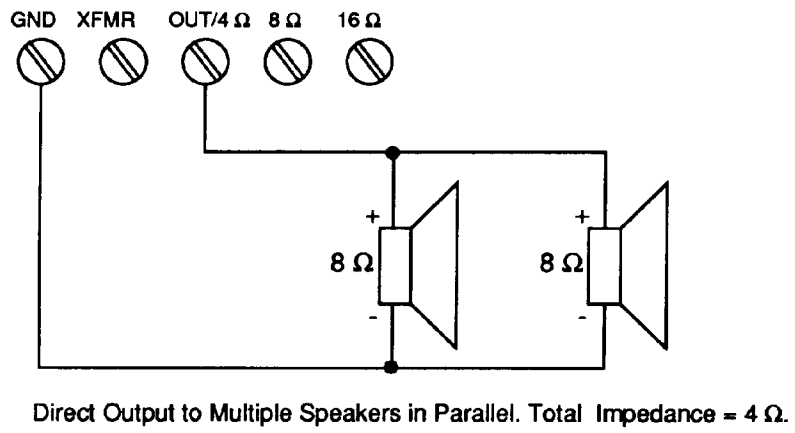
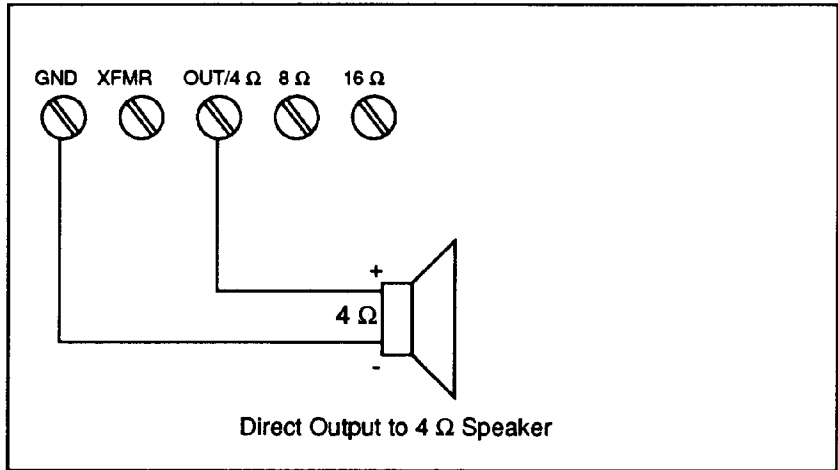

SPECIFICATIONS:

Output Power:

12 watts RMS

Power Bandwidth:

50 Hz - 20 kHz, 2% THD

60 Hz - 20 kHz, 1% THD

Frequency Response:

40 Hz - 20 kHz ± 1 dB

THD

0.25% @ 1 kHz, rated power

0.10% @ 1 kHz, 11 watts output power

S/N Ratio

(20 kHz bandwidth):

Master volume minimum

100 dB

Master volume maximum

78 dB

Tone Controls:

(Input 1 and PGM in only)

Bass ± 10 dB @ 100 Hz

Treble ± 10 dB @ 10 kHz

Contour:

(Input 1 and PGM in only)

+6 dB @ 100 Hz

+6 dB @ 10 kHz

Inputs:

Two input ports, each accepts any input/output module; one dedicated program input (dual RCA phono jacks)

Input Sensitivity:

Ports 1-2: 100 mV @ 10 K ohms

Program In: 100 mV @ 50 K ohms

Outputs:

Direct Out: 4 ohms

Transformer: 8 ohms, 16 ohms, 25V, 70V

Output Regulation:

Less than 0.5 dB, no load to full load

Controls:

3 input gain controls, 1 bass control, 1 treble control.

1 contour switch, 1 program gain limit control,

1 master gain control, 1 power switch

Indicators:

Power LED, bicolor (green/red) status LED

Protection:

Built-in, with AC Line fuse (external)

Connectors:

PGM input — RCA phono jacks

Ports 1-2 — Card edge connector

Outputs — Screw terminals

Mute — Screw terminals

AC line cord — SJT, 3 prong

Power Consumption

120 volts AC, 60 Hz, 30 watts

Dimensions

3.50" (H) x 12.00" (W) x 9.5" (D)

Weight:

9 lbs.

Color:

Gray

Standard Accessories

Tinted security cover

Other Features:

Inputs 1-2 and Program muted simultaneously

LIMITED WARRANTY

Peavey Electronics Corporation warrants to the original purchaser of this new Architectural Acoustics product that it is free from defects in material and workmanship. If within one (1) year from date of purchase a properly installed product proves to be defective and Peavey is notified, Peavey will repair or replace it at no charge. (Note: Batteries and patch cords not covered.) "Original purchaser" means the customer for whom the product is originally installed.

Damage resulting from improper installation, interconnection of a unit or system of another manufacturer, accident or unreasonable use, neglect or any other cause not arising from defects in material and workmanship is not covered by this warranty. The warranty is valid only as to products purchased and installed in the United States.

THIS LIMITED WARRANTY IS IN LIEU OF ANY AND ALL WARRANTIES, EXPRESSED OR IMPLIED, INCLUDING THE IMPLIED WARRANTIES OF MERCHANTABILITY AND FITNESS FOR A PARTICULAR USE. UNDER NO CIRCUMSTANCES WILL PEAVEY BE LIABLE FOR ANY LOST PROFITS, LOST SAVINGS, INCIDENTAL DAMAGES OR CONSEQUENTIAL DAMAGES ARISING OUT OF THE USE OR INABILITY TO USE THE PRODUCT, EVEN IF PEAVEY HAS BEEN ADVISED OF THE POSSIBILITY OF SUCH DAMAGE. THIS LIMITED WARRANTY IS THE ONLY EXPRESSED WARRANTY ON THIS PRODUCT, AND NO OTHER STATEMENT, REPRESENTATION, WARRANTY, OR AGREEMENT BY ANY PERSON SHALL BE VALID OR BINDING UPON PEAVEY.

Peavey's liability to the original purchaser for damages for any cause whatsoever and regardless of the form of action, is limited to the actual damages up to the greater of Five Hundred Dollars (\$500) or an amount equal to the purchase price of the product that caused the damage or that is the subject of or is directly related to the cause of action. This limitation of liability will not apply to claims for personal injury or damage to real property or tangible personal property allegedly caused by Peavey's negligence. For information on service under this warranty, call a Peavey customer service representative at (601) 483-5376.

DANGER

EXPOSURE TO EXTREMELY HIGH NOISE LEVELS MAY CAUSE A PERMANENT HEARING LOSS. INDIVIDUALS VARY CONSIDERABLY IN SUSCEPTIBILITY TO NOISE INDUCED HEARING LOSS, BUT NEARLY EVERYONE WILL LOSE SOME HEARING IF EXPOSED TO SUFFICIENTLY INTENSE NOISE FOR A SUFFICIENT TIME. THE U.S. GOVERNMENT'S OCCUPATIONAL SAFETY AND HEALTH ADMINISTRATION (OSHA) HAS SPECIFIED THE FOLLOWING PERMISSIBLE NOISE LEVEL EXPOSURES:

DURATION PER DAY IN HOURS	SOUND LEVEL DBA, 90% BLOW RESPONSE
8	90
6	92
4	95
3	97
2	100
1 1/2	102
1	105
7/8	110
1/2	115

ACCORDING TO OSHA, ANY EXPOSURE IN EXCESS OF THE ABOVE PERMISSIBLE LIMITS COULD RESULT IN SOME HEARING LOSS. EAR PLUGS OR PROTECTORS IN THE EAR CANALS OR OVER THE EAR MUST BE WORN WHEN OPERATING THIS AMPLIFICATION SYSTEM IN ORDER TO PREVENT A PERMANENT HEARING LOSS IF EXPOSURE IS IN EXCESS OF THE LIMITS AS SET FORTH ABOVE. TO INSURE AGAINST POTENTIALLY DANGEROUS EXPOSURE TO HIGH NOISE PRESSURE LEVELS, IT IS RECOMMENDED THAT ALL PERSONS EXPOSED TO EQUIPMENT CAPABLE OF PRODUCING HIGH SOUND PRESSURE LEVELS SUCH AS THIS AMPLIFICATION SYSTEM BE PROTECTED BY WEARING PROTECTIVE EARPLUGS WHILE THE UNIT IS IN OPERATION.

CAUTION

THIS AMPLIFIER HAS BEEN DESIGNED AND CONSTRUCTED TO PROVIDE ADEQUATE POWER RESERVE FOR PLAYING MODERN MUSIC WHICH MAY REQUIRE OCCASIONAL PEAK POWER TO HANDLE OCCASIONAL PEAK POWER. ADEQUATE POWER HEADROOM HAS BEEN DESIGNED INTO THIS SYSTEM FOR EXTENDED OPERATION AT ABSOLUTE MAXIMUM POWER LEVELS. BE AWARE THAT MAXIMUM POWER CAN BE OBTAINED WITH VERY LOW SETTINGS OF THE GAIN CONTROLS IF THE INPUT SIGNAL IS VERY STRONG.

1. Read all safety and operating instructions before using this product.
2. All safety and operating instructions should be retained for future reference.
3. Obey all cautions in the operating instructions and on the back of the unit.
4. All operating instructions should be followed.
5. This product should not be used near water, i.e. a bathtub, sink, swimming pool, wet basement, etc.
6. This product should be located so that its position does not interfere with its proper ventilation. It should not be placed flat against a wall or placed in a built-in enclosure that will impede the flow of cooling air.
7. This product should not be placed near a source of heat such as a stove, radiator or another heat producing amplifier.
8. Connect only to a power supply of the type marked on the unit adjacent to the power supply cord.
9. Never touch off the ground pin on the power supply cord. For more information on grounding write for our free booklet "Shock Hazard and Grounding".
10. Power supply cords should always be handled carefully. Never walk or place equipment on power supply cords. Periodically check cords for cuts or signs of stress especially at the plug and the point where the cord exits the unit.
11. The power supply cord should be unplugged when the unit is to be unused for long periods of time.
12. If this product is to be mounted in an equipment rack, rear support should be provided.
13. Metal parts can be cleaned with a damp rag. The vinyl control knobs on some units can be cleaned with a damp rag. Do not use ammonia based household cleaner if necessary.
14. Care should be taken so that objects do not fall and liquids are not spilled into the unit through the ventilation holes or any other openings.
15. This unit should be checked by a qualified service technician if:
 - A. The power supply cord or plug has been damaged
 - B. Anything has fallen or been spilled into the unit.
 - C. The unit does not operate correctly.
 - D. The unit has been dropped or the enclosure damaged.
16. The user should not attempt to service this equipment. All service work should be done by a qualified service technician.



Features and specifications subject to change without notice.

A Division of Peavey Electronics Corporation

711 A Street, P. O. Box 2898, Meridian, MS 39302-2898 / (601) 483-5376 / Telex 504115 / Fax (601) 484-4278

#80301352