

*OPERATING INSTRUCTIONS*

***IPA™/150***

***HIGH PERFORMANCE***

***UTILITY AMPLIFIER***



***PEAVEY™***

**ARCHITECTURAL  
ACOUSTICS™**

**CAUTION: TO PREVENT ELECTRICAL SHOCK OR FIRE HAZARD, DO NOT EXPOSE THIS APPLIANCE TO RAIN OR MOISTURE. BEFORE USING THIS APPLIANCE, READ BACK COVER FOR FURTHER WARNINGS.**

**DESCRIPTION**

The IPA™/150 is a high performance utility amplifier designed to meet the needs of the most demanding fixed installation/PA application. The convenient patch panel layout, coupled with state-of-the-art circuit design, assures reliable long-term operation and smooth trouble-free installation.

Twenty-five and seventy volt line output capability is standard equipment. The IPA/150 has been packaged for standard 19" "rack-mount" capability and occupies only two vertical rack spaces. A smoke-tinted security cover has been provided with a "snap-on" feature to guard against accidental or malicious alteration of system calibration.

**FEATURES**

**POWER OUTPUT:**

- 150 Watts RMS into 4 ohms

**CONTROLS AND INDICATORS:**

- Level control
- Subsonic filter switch
- Power on LED
- Power switch

**OUTPUTS:**

- 4 ohm/25 volt screw terminal output
- 8 ohm screw terminal output
- 16 ohm screw terminal output
- 1V/600 ohm balanced output
- AC convenience outlet

**FRONT PANEL**

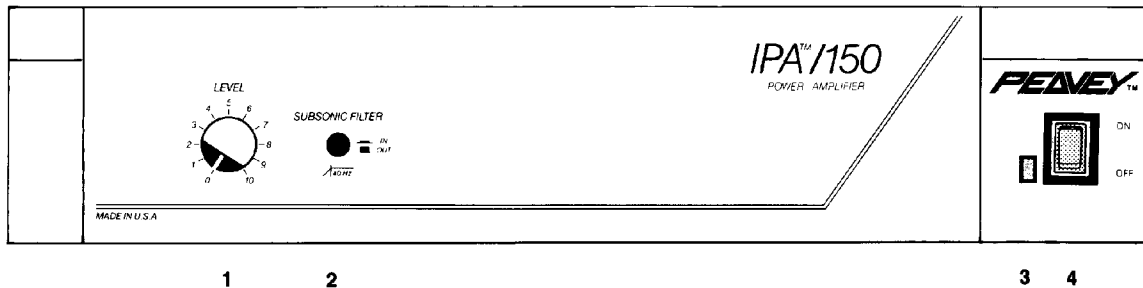

**LEVEL (1)**

Controls the volume level of the system.

**SUBSONIC FILTER (2)**

The "in" position of this switch activates the 18 dB/octave subsonic filter at 42 Hz. The "out" position removes the subsonic filter from the system.

**POWER ON LED (3)**

Indicates when AC power is being supplied to the unit.

**POWER SWITCH (4)**

Depress to "on" position to turn on.

**REAR PANEL**

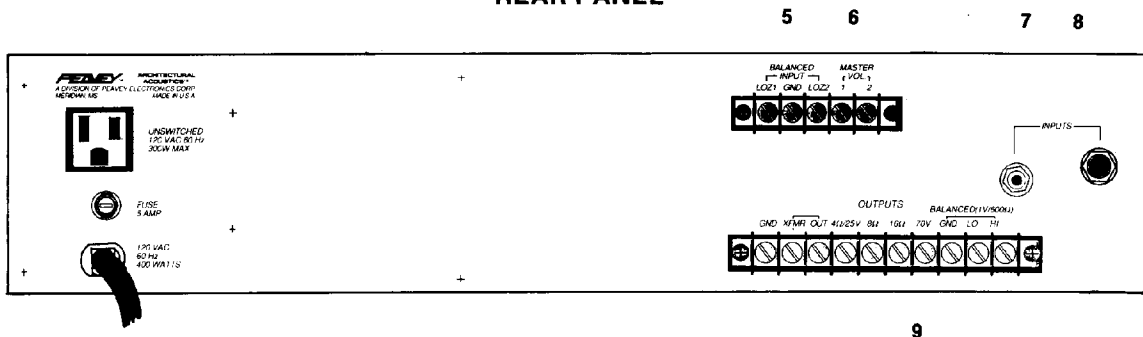

**LINE INPUTS (5)**

The input connections are configured to allow balanced and unbalanced signals to be connected to the system. See figures 1 and 2.

**EXTERNAL MASTER VOLUME (6)**

These terminals allow connection of an external volume control. To gain complete control of volume from an external volume control, the front panel "level" control must be set to maximum. The external volume control should be connected as shown in figure 3.

**RCA INPUT JACK (7)**

The RCA line input is paralleled with other inputs. See figure 4 concerning use of this jack.

**1/4" INPUT JACK (8)**

The 1/4" phone input allows balanced operation (RTS).

**OUTPUTS (9)**

A direct output, as well as several autoformer outputs, are provided to allow the proper interface between the amplifier and the speaker system. The direct output allows direct connection to a 4 ohm speaker system. To use this

output, disconnect the jumper between the OUT terminal and the XFMR terminal. Connect the speaker (or speakers) between the GND terminal and the output terminal. 8 ohm, 16 ohm, 25 volt and 70 volt outputs are also provided. To use these outputs, the jumper between OUT and XFMR must be installed. For 8 ohm speaker systems, connect between the GND terminal and the 8 ohm terminal. 16 ohm speaker systems should be connected between the GND terminal and the 16 ohm terminal. 25V and 70V outputs are also provided for "constant voltage" speaker distribution systems. The connection for distributed systems is between the GND terminal and either the 25V or 70V terminals, depending on the required system voltage. NOTE: a 25 volt line is available from the 4 ohm/25V terminal only with the jumper installed between the XFMR terminal and the OUT terminal.

One more output is provided on the IPA/150 amplifier. This is a balanced, transformer isolated line level output. This output is provided for direct connection to "music on hold" systems, booster power amplifiers, etc. This output is designed to deliver 1V RMS into a 600 ohm load. See figure 5 through 9 for possible output connections.

**INSTALLATION INFORMATION  
POWER AND GROUNDING:**

For your safety, we have incorporated a 3-wire line (mains) cable with proper grounding facilities. It is not advisable to remove the ground pin under any circumstances. If it is necessary to use the equipment without proper grounding facilities, suitable grounding adaptors

should be used. Less noise and greatly reduced shock hazard exist when the unit is operated with the proper grounded receptacles.

**INSTALLING THE RACK-MOUNT EARS**

This unit is shipped with the rack-mount ears uninstalled. To attach the rack-mount ears, simply remove the three screws already in the front on either side of unit and align the ears with the rack-mount flange forward of the unit. Replace the screws and tighten securely, being careful not to overtighten. The unit then mounts in a standard 2 space 19" rack. You may find it desirable to remove the rubber feet from the bottom of the unit in rack-mount installations. The rack-mount ears may also be used to secure the unit in a shelf application to deter theft.

**RACK-MOUNT RECOMMENDATION**

To provide adequate ventilation, leave at least one rack space between units when multiple amplifiers are mounted in the same rack.

**REMOVING AND REPLACING THE SECURITY COVER**

To remove the cover, insert a standard flat head screwdriver into the slot on either side of the cover. With a gentle inward pressure, "pop" the cover out. To replace the cover, simply align it with the front of the unit and push securely into place.

**ARCHITECTURAL & ENGINEERING SPECIFICATIONS**

The power amplifier shall have one input that has provisions for both balanced and unbalanced signals. Connections for the balanced input shall be provided via a (RTS) 1/4" jack or by barrier strip connections. Connections for the unbalanced input shall be provided by the (RTS) 1/4" jack, the barrier strip connections, and the RCA phono jack.

Provision for an external master volume control shall be made via barrier strip connections on the back panel. The unit shall be packaged in a rugged metal chassis 17" wide by 3 1/2" high by 15 3/4" deep (including external heatsinks). The unit shall operate from standard 120 volts AC, 60 Hz power. The power amplifier shall be capable of delivering 150 Watts into 4 ohms, 8 ohms, and 16 ohms, as well as providing 25 volt and 70 volt line outputs. The unit shall be capable of delivering 40 Hz to 20 kHz rated power from +0/-1 dB into 4 ohms at its direct output at .5% or less distortion with system hum and noise at least 95 dB below rated output. The unit shall be called the Peavey Architectural Acoustics™ Division model IPA™/150.

**RATED POWER & LOAD**

Direct Output: 150W RMS @ 4 ohms

Transformer Output: 150W RMS @ 4 ohms (25V)/33 ohms (70V)

**DISTORTION**

.5% THD @ rated power

**FREQUENCY RESPONSE**

Direct Output: +0/-1 dB 40 Hz to 20 kHz

**HUM AND NOISE**

Greater than 95 dB below rated power

**INPUT SENSITIVITY**

0.87V RMS

**SUBSONIC FILTER**

Provides an 18 dB per octave roll off of low frequencies with the 3 dB point at 42 Hz

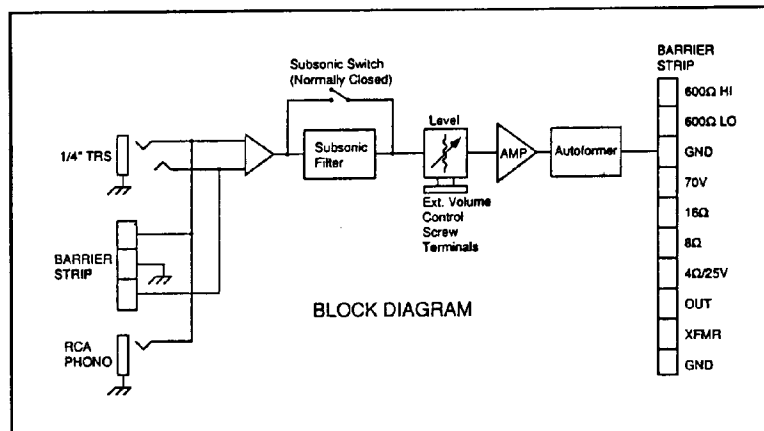

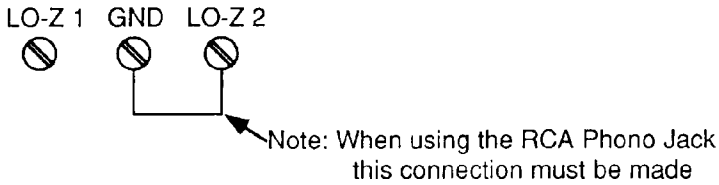
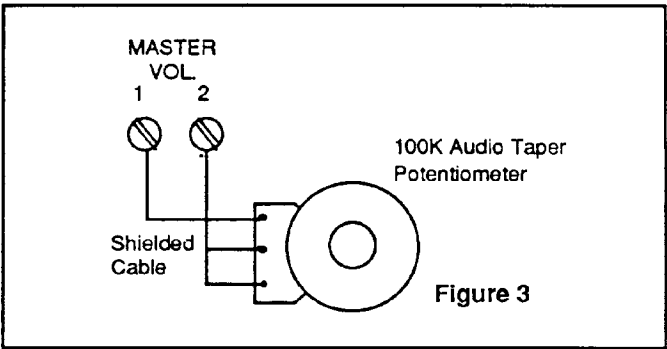
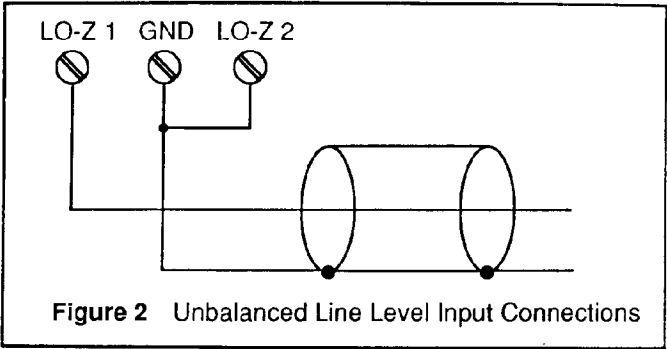
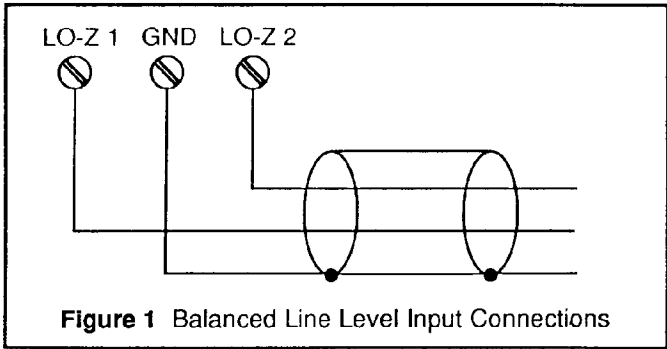

**Figure 4** RCA Phono Jack Configuration of Barrier Strip

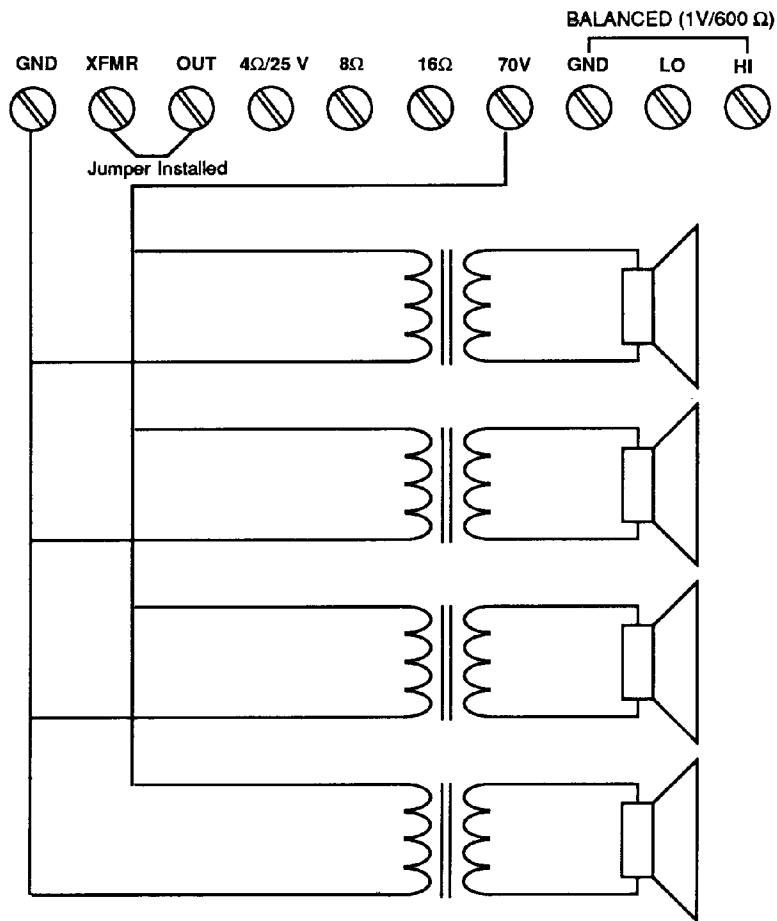

Figure 5. 70 V "Constant Voltage" Distribution System

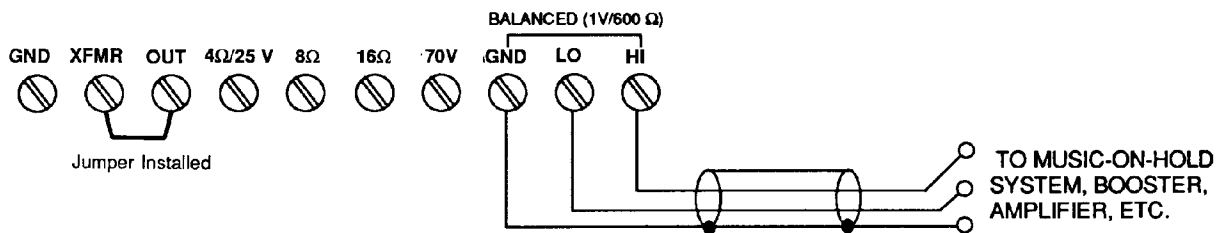
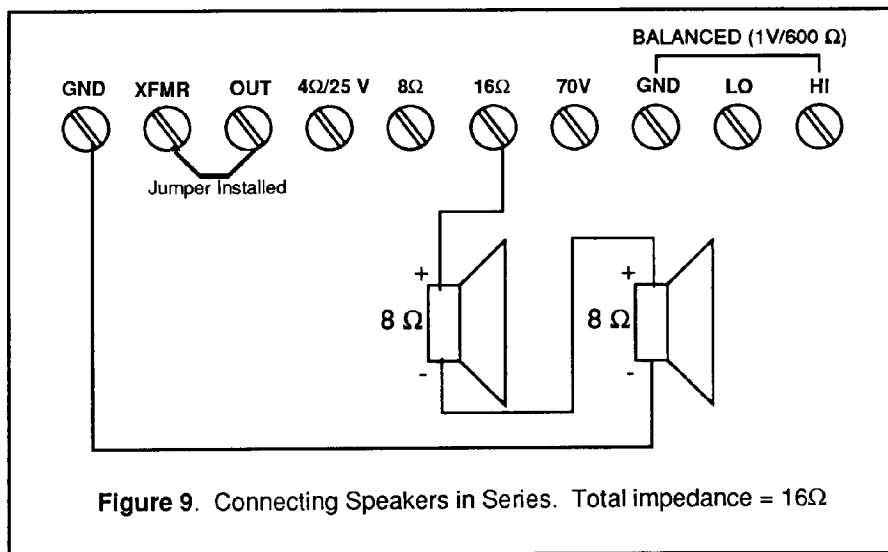
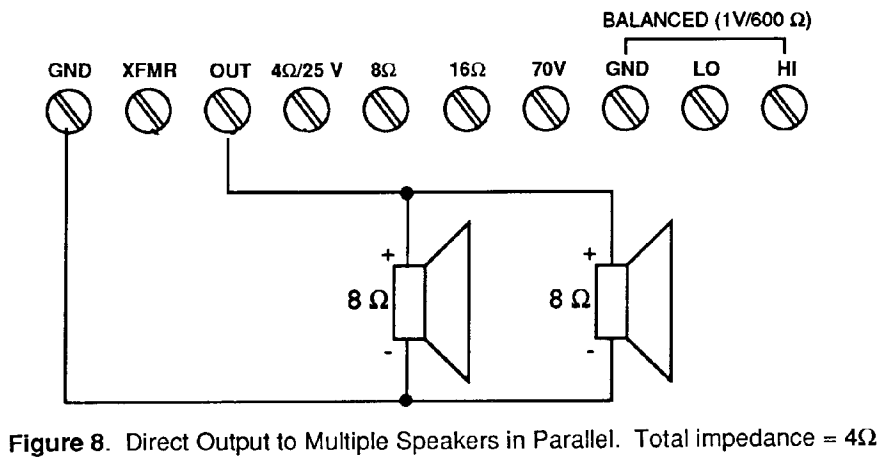
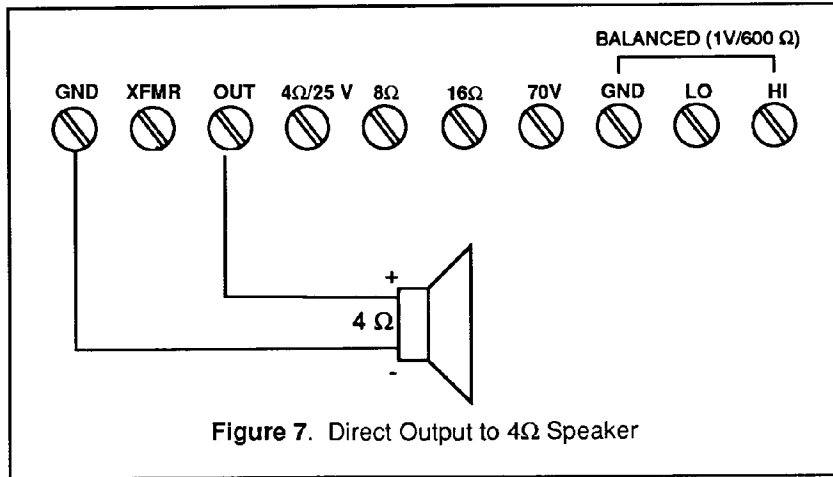

Figure 6. 1 V Balanced Output Connectors

**NOTE: ALL DIAGRAMS ARE OF IPA™ / 150 BACK PANEL**



## WARRANTY

Peavey Electronics Corporation warrants to the original purchaser of this new Architectural Acoustics™ product that it is free from defects in material and workmanship. If within one (1) year from date of purchase a properly installed product proves to be defective and Peavey is notified, Peavey will repair or replace it at no charge. (Note: Batteries and patch cords not covered.) "Original purchaser" means the customer for whom the product is originally installed. Damage resulting from improper installation, interconnection of a unit or system of another manufacturer, accident or unreasonable use, neglect or any other cause not arising from defects in material and workmanship is not covered by this warranty. The warranty is valid only as to products purchased and installed in the United States.

**THIS LIMITED WARRANTY IS IN LIEU OF ANY AND ALL WARRANTIES, EXPRESSED OR IMPLIED, INCLUDING THE IMPLIED WARRANTIES OF MERCHANTABILITY AND FITNESS FOR A PARTICULAR USE. UNDER NO CIRCUMSTANCES WILL PEAVEY BE LIABLE FOR ANY LOST PROFITS, LOST SAVINGS, INCIDENTAL DAMAGES OR CONSEQUENTIAL DAMAGES ARISING OUT OF THE USE OR INABILITY TO USE THE PRODUCT, EVEN IF PEAVEY HAS BEEN ADVISED OF THE POSSIBILITY OF SUCH DAMAGE. THIS LIMITED WARRANTY IS THE ONLY EXPRESS WARRANTY ON THIS PRODUCT, AND NO OTHER STATEMENT, REPRESENTATION, WARRANTY OR AGREEMENT BY ANY PERSON SHALL BE VALID OR BINDING UPON PEAVEY.**

Peavey's liability to the original purchaser for damages for any cause whatsoever and regardless of the form of action, is limited to the actual damages up to the greater of Five Hundred Dollars (\$500) or an amount equal to the purchase price of the product that caused the damage or that is the subject of or is directly related to the cause of action. This limitation of liability will not apply to claims for personal injury or damage to real property or tangible personal property allegedly caused by Peavey's negligence. For information on service under this warranty, call a Peavey customer service representative at (601) 483-5376.

**DANGER**

EXPOSURE TO EXTREMELY HIGH NOISE LEVELS MAY CAUSE A PERMANENT HEARING LOSS. INDIVIDUALS VARY CONSIDERABLY IN SUSCEPTIBILITY TO NOISE INDUCED HEARING LOSS. BUT NEARLY EVERYONE WILL LOSE SOME HEARING IF EXPOSED TO SUFFICIENTLY INTENSE NOISE FOR A SUFFICIENT TIME. THE U.S. GOVERNMENT'S OCCUPATIONAL SAFETY AND HEALTH ADMINISTRATION (OSHA) HAS SPECIFIED THE FOLLOWING PERMISSIBLE NOISE LEVEL EXPOSURES:

DURATION PER DAY IN HOURS	SOUND LEVEL dBA, SLOW RESPONSE
8	90
6	92
4	95
3	97
2	100
1 1/2	102
1	105
7/8	110
1/2	115

ACCORDING TO OSHA, ANY EXPOSURE IN EXCESS OF THE ABOVE PERMISSIBLE LIMITS COULD RESULT IN SOME HEARING LOSS. EAR PLUGS OR PROTECTORS IN THE EAR CANALS OR OVER THE EARS MUST BE WORN WHEN OPERATING THIS AMPLIFICATION SYSTEM IN ORDER TO PREVENT A PERMANENT HEARING LOSS IF EXPOSURE IS IN EXCESS OF THE LIMITS AS SET FORTH ABOVE. TO INSURE AGAINST POTENTIALLY DANGEROUS EXPOSURE TO HIGH SOUND PRESSURE LEVELS, IT IS RECOMMENDED THAT ALL PERSONS EXPOSED TO EQUIPMENT CAPABLE OF PRODUCING HIGH SOUND PRESSURE LEVELS SUCH AS THIS AMPLIFICATION SYSTEM BE PROTECTED BY HEARING PROTECTORS WHILE THIS UNIT IS IN OPERATION.

**CAUTION**

THIS AMPLIFIER HAS BEEN DESIGNED AND CONSTRUCTED TO PROVIDE ADEQUATE POWER RESERVE FOR PLAYING MODERN MUSIC WHICH MAY REQUIRE OCCASIONAL PEAK POWER. TO HANDLE OCCASIONAL PEAK POWER, ADEQUATE POWER "HEADROOM" HAS BEEN DESIGNED INTO THIS SYSTEM. EXTENDED OPERATION AT ABSOLUTE MAXIMUM POWER LEVELS IS NOT RECOMMENDED SINCE THIS COULD DAMAGE THE ASSOCIATED LOUDSPEAKER SYSTEM. PLEASE BE AWARE THAT MAXIMUM POWER CAN BE OBTAINED WITH VERY LOW SETTINGS OF THE GAIN CONTROLS IF THE INPUT SIGNAL IS VERY STRONG.

1. Read all safety and operating instructions before using this product.
2. All safety and operating instructions should be retained for future reference.
3. Obey all cautions in the operating instructions and on the back of the unit.
4. All operating instructions should be followed.
5. This product should not be used near water, i.e. a bathtub, sink, swimming pool, wet basement, etc.
6. This product should be located so that its position does not interfere with its proper ventilation. It should not be placed flat against a wall or placed in a built-in enclosure that will impede the flow of cooling air.
7. This product should not be placed near a source of heat such as a stove, radiator or another heat producing amplifier.
8. Connect only to a power supply of the type marked on the unit adjacent to the power supply cord.
9. Never break off the ground pin on the power supply cord. For more information on grounding, write for our free booklet, "Shock Hazard and Grounding".
10. Power supply cords should always be handled carefully. Never walk or place equipment on power supply cords. Periodically check cords for cuts or signs of stress, especially at the plug and the point where the cord exits the unit.
11. The power supply cord should be unplugged when the unit is to be unused for long periods of time.
12. If this product is to be mounted in an equipment rack, rear support should be provided.
13. Metal parts can be cleaned with a damp rag. The vinyl covering used on some units can be cleaned with a damp rag, or an ammonia based household cleaner if necessary.
14. Care should be taken so that objects do not fall and liquids are not spilled into the unit through the ventilation holes or any other openings.
15. This unit should be checked by a qualified service technician if:
  - A. The power supply cord or plug has been damaged.
  - B. Anything has fallen or been spilled into the unit.
  - C. The unit does not operate correctly.
  - D. The unit has been dropped or the enclosure damaged.
16. The user should not attempt to service this equipment. All service work should be done by a qualified service technician.



**PEAVEY**™  
A R C H I T E C T U R A L  
A C O U S T I C S™

Features and specifications subject to change without notice.

**A Division Of Peavey Electronics Corporation** / 711 A Street / P.O. Box 2898 / Meridian, MS 39302-2898 / U.S.A. / (601) 483-5376 Telex: 504115 / Fax: 484-4278  
©1989 Printed in the U.S.A. #80301027 2/89